



## Spare Parts Catalogue

ASKO Tumble Dryers \ ASKO XXL Series  
Type: TLS752G  
Model: TLS752GXXL Gas dryer

Prod. No: 107752GPP  
April 6th 2010

**ASKO Appliances Inc.**

4001 E Plano Parkway #1004001 E Plano Parkway #100  
Plano, Texas 75074

# Parts List by Ass'y

## 1. DRYER CABINET ASS'Y

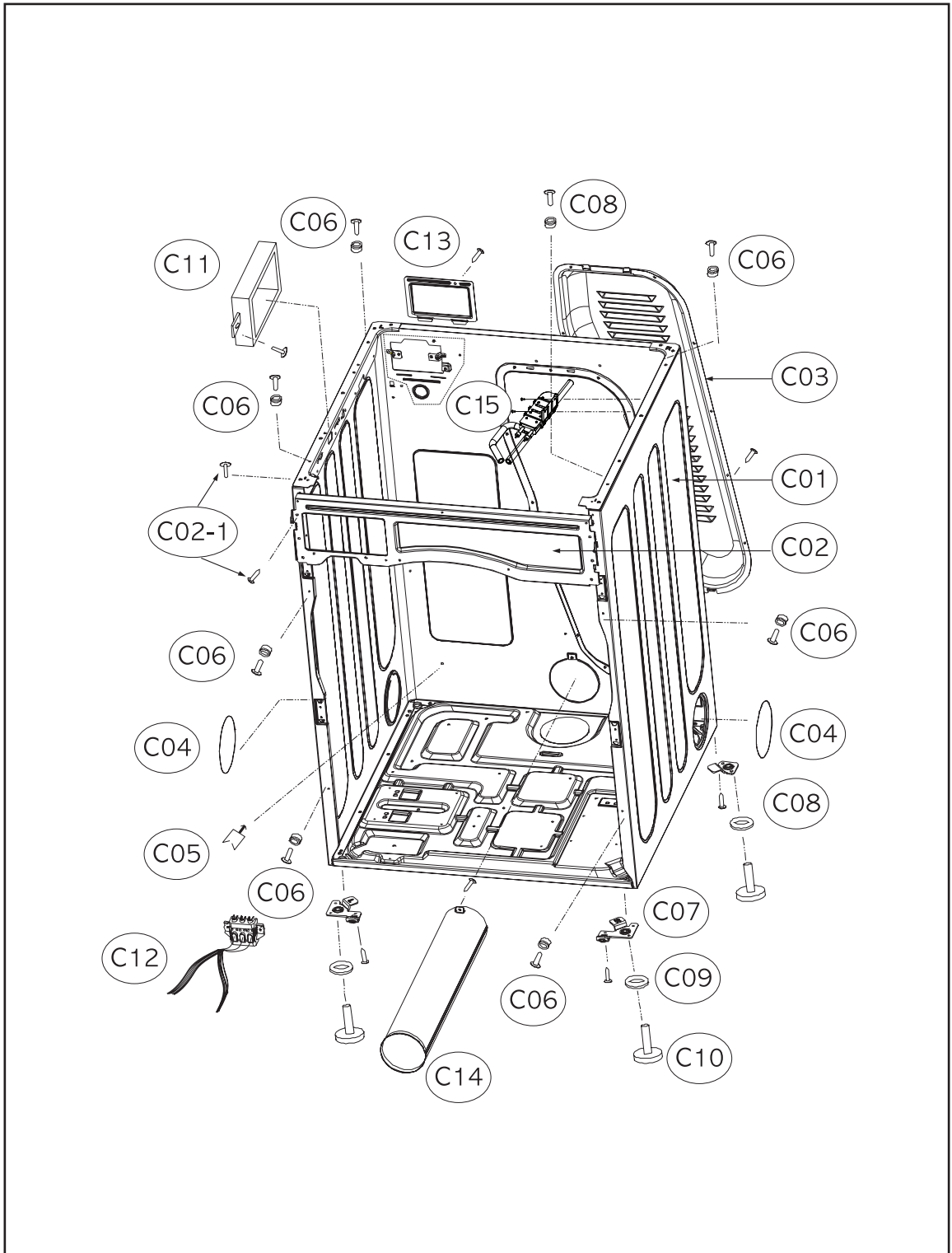

## Cabinet

### ASKO, TLS752GXXL - Gas dryer #107752GPP (TLS752G)

Pos	Spare part No.	Description	Qty	Comment
C02	3612207900	Front Frame Upper	1 Pc's	
C02-a	7121401411	Screw - Self Tapping	6 Pc's	
C03	3611427900	Back Cover	1 Pc's	
C03	3612206500	Frame Top - Left	1 Pc's	
C03-a	7112401411	Screw-Self Tapping	12 Pc's	
C04	3612206600	Frame Top - Right	1 Pc's	
C04	3610392900	Base	1 Pc's	
C04	3611428010PP	Duct Cover	2 Pc's	
C06	3612008000	Panel Clip	6 Pc's	
C06-a	7121401211	Screw - Self Tapping	6 Pc's	
C07	3615304200	Front Leg Support	2 Pc's	
C08	3615304300	Rear Leg Support	2 Pc's	
C09	3612006400	Leg Locking Nut	4 Pc's	
C10	3612100700	Leg Adjustable	4 Pc's	
C10-a	7122401411	Screw - Self Tapping	2 Pc's	
C11	PRPSSWAD47	PCB DRYER GAS MAIN AS	1 Pc's	
C12	3612797320	Harness, G-Dryer Main, Hot steam	1 Pc's	
C12-a	7121401411	Screw - Self Tapping	6 Pc's	
C12-b	7S422X4081	Earth Ground Screw	2 Pc's	
C13	3611428100	Terminal Block Cover	1 Pc's	
C13-a	7112401411	Screw-Self Tapping	1 Pc's	
C14	3614413600	Exhaust Pipe	1 Pc's	
C14-a	7112401008	Screw-Self Tapping	1 Pc's	
C15	3619606900	UNIT STEAM DRYER AS	1 Pc's	
C15-a	7122401411	Screw - Self Tapping	2 Pc's	

## 8. DOOR ASS'Y

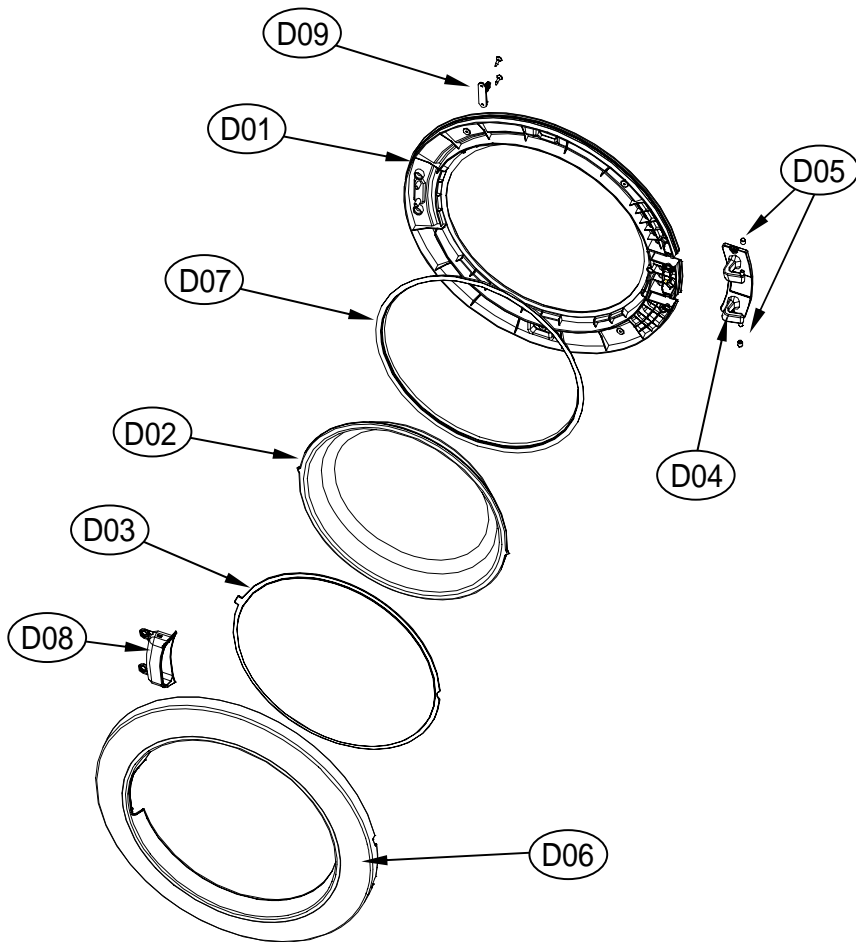

## Door Assembly

ASKO, TLS752GXXL - Gas dryer #107752GPP (TLS752G)

Pos	Spare part No.	Description	Qty	Comment
D01	3612208000	Door Frame - Inner	1 Pc's	
D01-a	7115402008	Screw - Self Tapping	15 Pc's	
D02	36117ABR00	Door Glass	1 Pc's	
D03	3618304300	Door Glass Protection	1 Pc's	
D04	3612903600PP	Door Hinge	1 Pc's	
D05	3610916500PP	Door Hinge Cap	2 Pc's	
D06	3612208110PP	Door Frame - Outer	1 Pc's	
D07	3612323000	Door Gasket	1 Pc's	
D08	3611428310PP	Handle Cover	1 Pc's	
D09	3613101100	Door Hook	1 Pc's	
D09-a	7115401608	Screw-Self Tapping	1 Pc's	

## 12. UNIT STEAM DRYER AS & UNIT COLD SPRAY AS

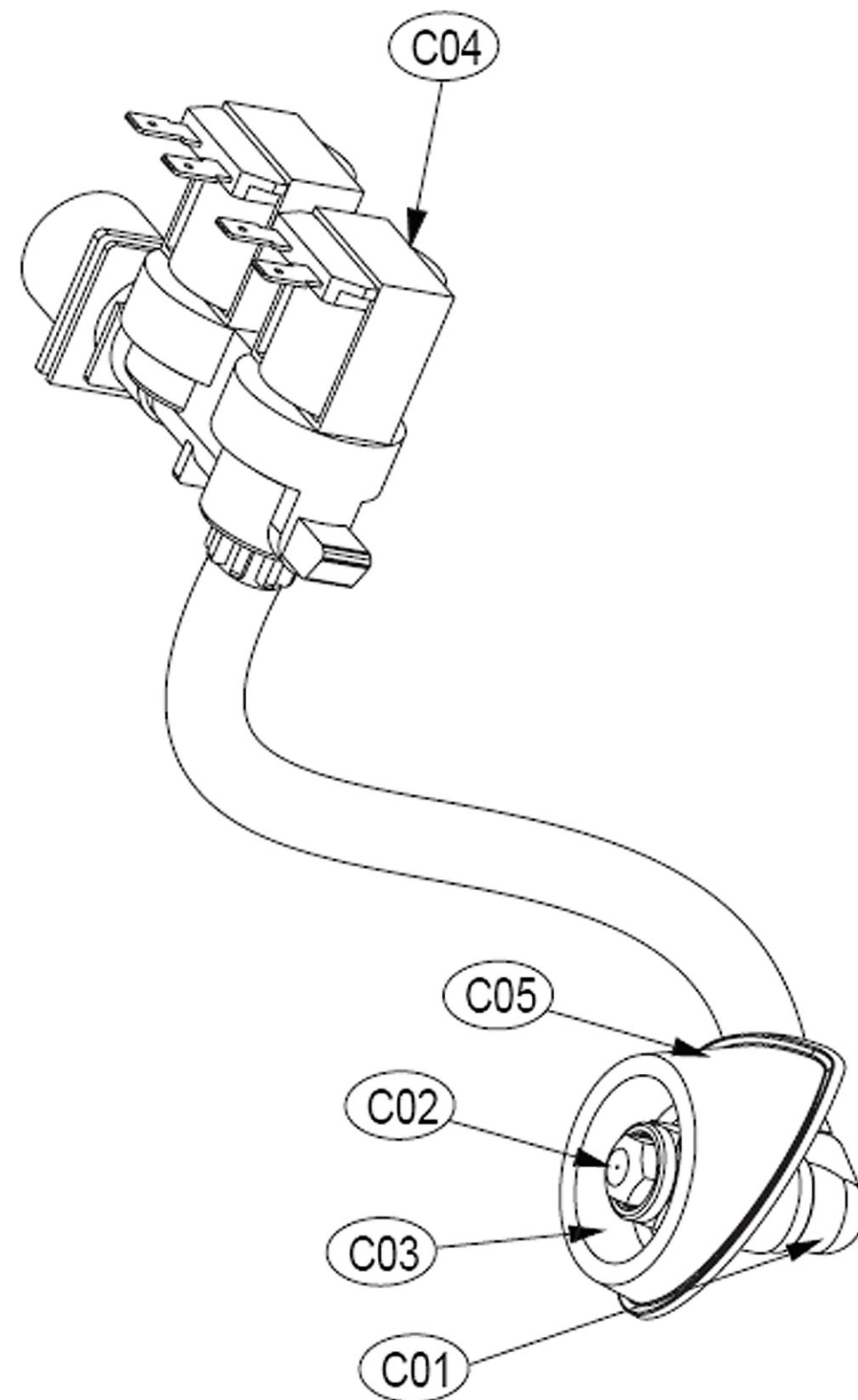
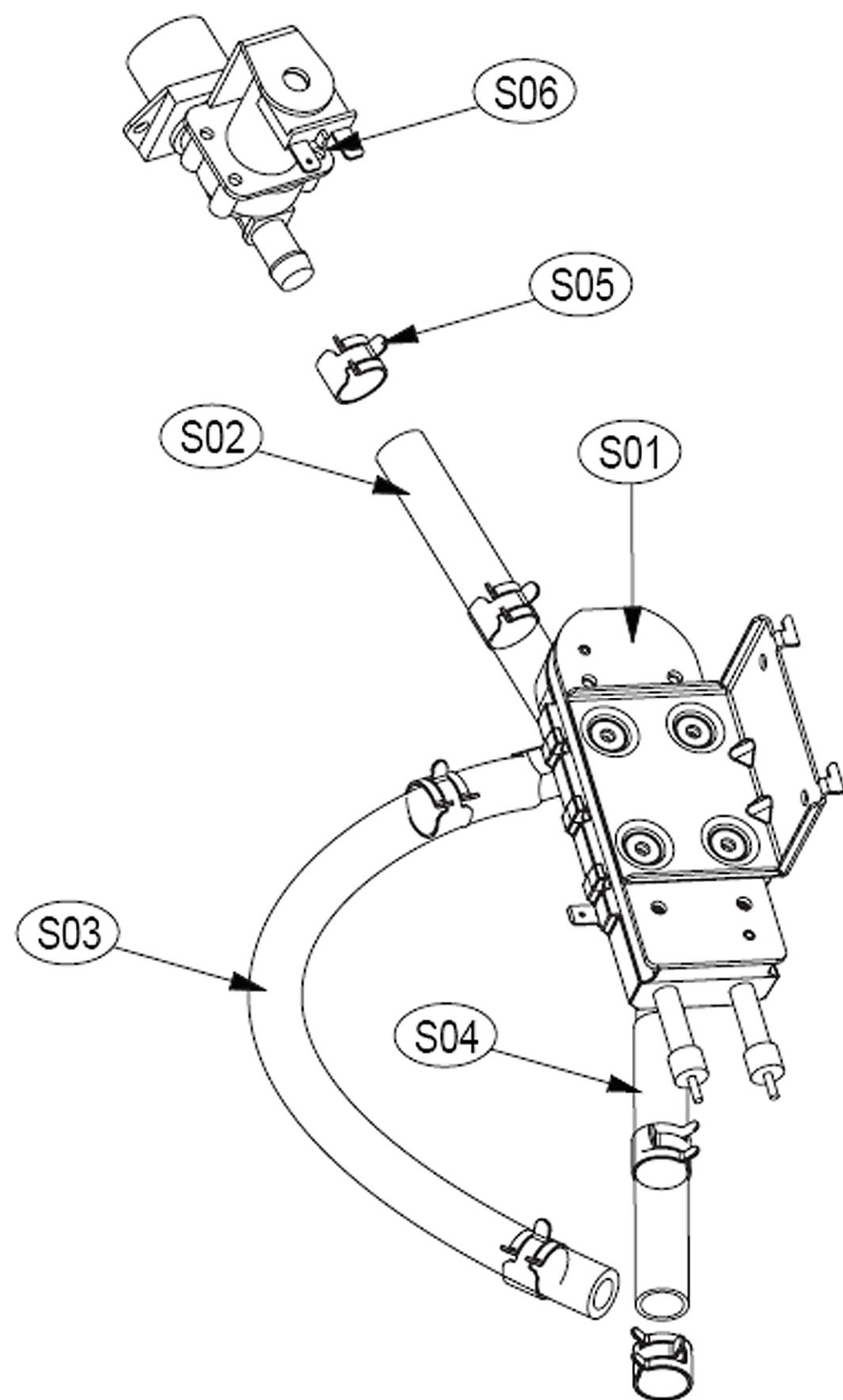

## **Inlet System**

**ASKO, TLS752GXXL - Gas dryer #107752GPP (TLS752G)**

<b>Pos</b>	<b>Spare part No.</b>	<b>Description</b>	<b>Qty</b>	<b>Comment</b>
C01	36104PWE00	BODY COLD SPRAY AS	1 Pc's	
C02	3618110900	JET NOZZLE AS	1 Pc's	
C03	3616063800	NUT HEX	1 Pc's	
C04	3615417900	VALVE INLET	1 Pc's	
C05	3610919300	CAP BODY	1 Pc's	
C05-a	7112401208	Screw-Self Tapping	2 Pc's	
S01	3619606700	UNIT STEAM AS	1 Pc's	
S02-S04	3613275100	HOSE SPRAY	1 Pc's	
S05	3611205830	CLAMP HOSE	1 Pc's	
S06	3615416731	VALVE INLET	1 Pc's	
S06	3619607000	UNIT COLD SPRAY AS	1 Pc's	
S06-a	7122401411	Screw - Self Tapping	2 Pc's	

## 7. TOP PANEL ASS'Y

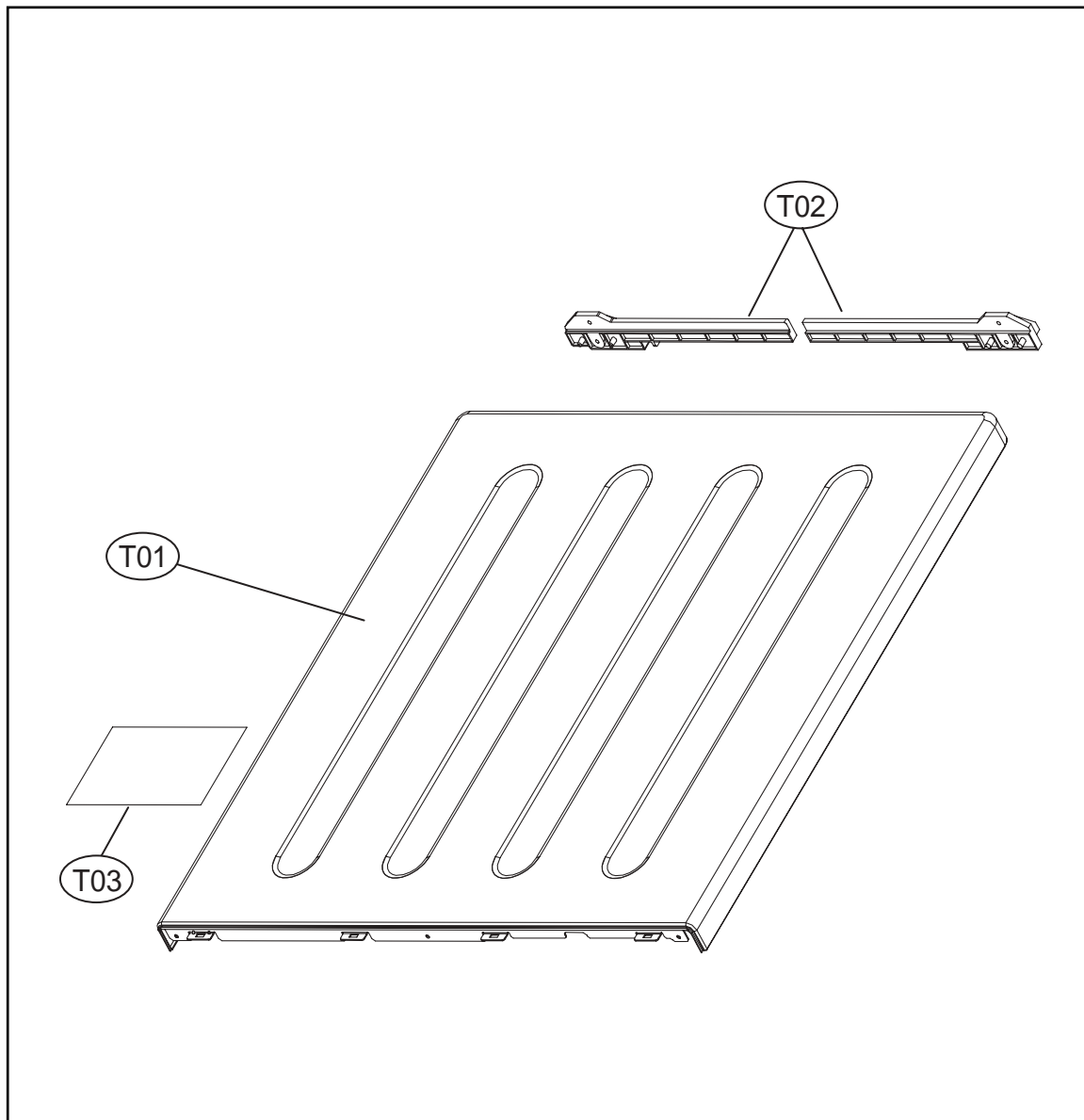



## Top Lid

ASKO, TLS752GXXL - Gas dryer #107752GPP (TLS752G)

Pos	Spare part No.	Description	Qty	Comment
T01	PRMACA3R20	Top Panel Platinum	1 Pc's	
T02	3615304100	Top Panel Support	2 Pc's	
T02-a	7122401411	Screw - Self Tapping	4 Pc's	

# 5. DRUM SUPPORT REAR ASS'Y

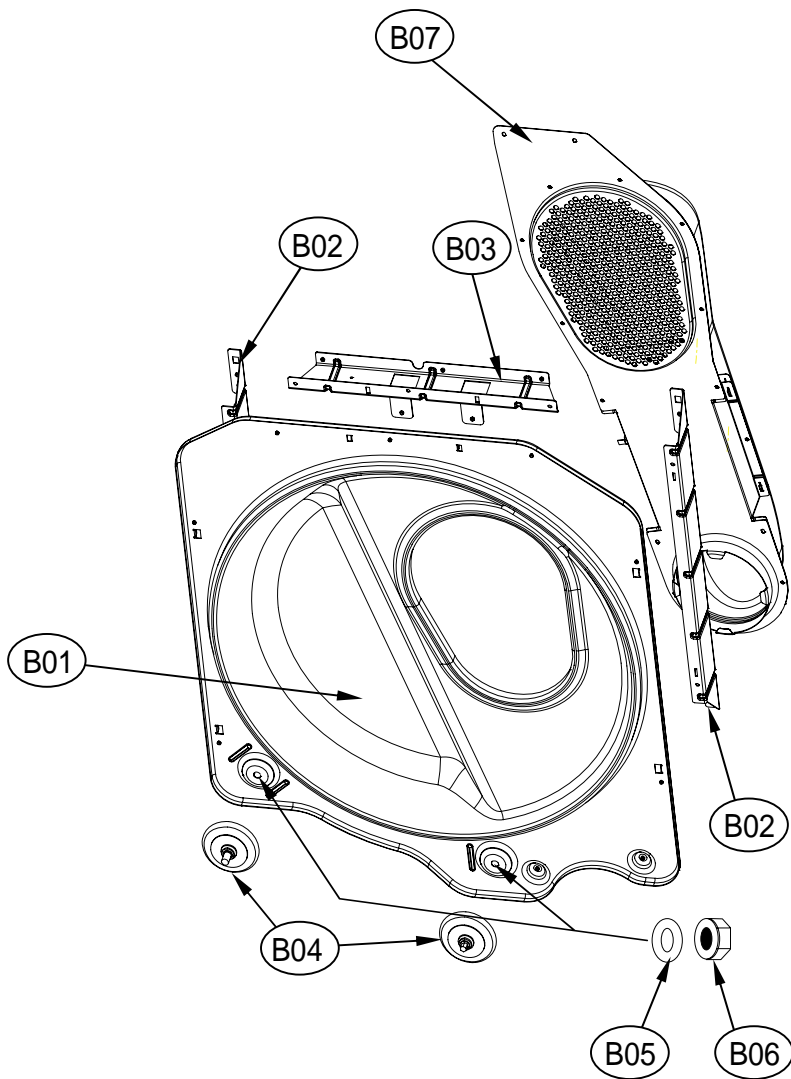

## **Rear Assembly Dryer Drum**

**ASKO, TLS752GXXL - Gas dryer #107752GPP (TLS752G)**

<b>Pos</b>	<b>Spare part No.</b>	<b>Description</b>	<b>Qty</b>	<b>Comment</b>
B01	3615304500	Drum Support Rear	1 Pc's	
B02	3610608810	Support Bracket Right Side	1 Pc's	
B02-a	7122401411	Screw - Self Tapping	7 Pc's	
B03	3610608910	Support Bracket Right Upper	1 Pc's	
B03-a	7122401411	Screw - Self Tapping	7 Pc's	
B04	3614714400	Drum Roller	2 Pc's	
B05	3616039400	Washer - Roller	2 Pc's	
B06	3616039300	Nut - Roller	2 Pc's	
B07	3617510110	DUCT INLET AS GAS	1 Pc's	

## 2. DRYER MOTOR ASS'Y

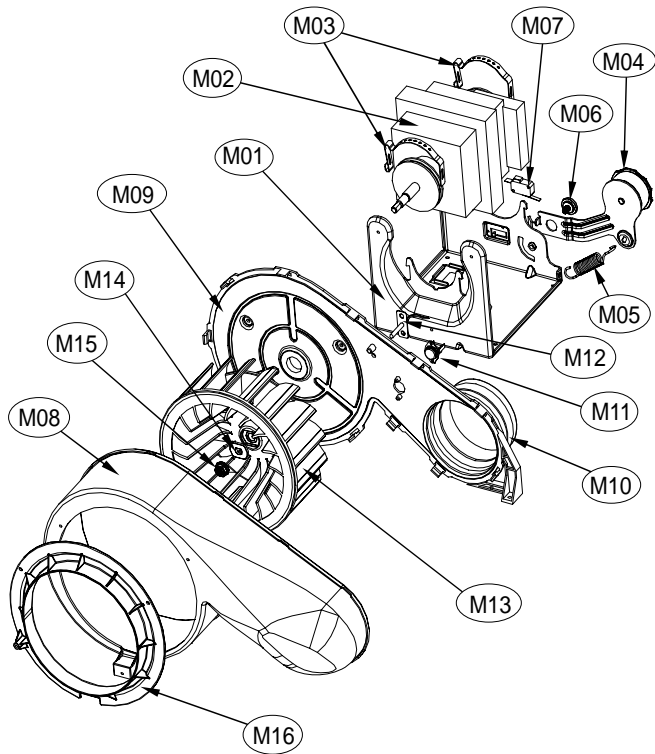

## Motor ass'y dryer

ASKO, TLS752GXXL - Gas dryer #107752GPP (TLS752G)

Pos	Spare part No.	Description	Qty	Comment
M01	3610608500	Motor Bracket	1 Pc's	
M02	36189L5D00	Dryer Motor	1 Pc's	
M03	3611206000	Motor Clamp	2 Pc's	
M04	3610609100	Idler Bracket	1 Pc's	
M05	3615115500	Idler Spring	1 Pc's	
M06	3616039000	Idler Bolt	1 Pc's	
M07	3619047500	Micro Switch	1 Pc's	
M07-a	7121301611	Screw-Self Tapping	2 Pc's	
M08	3611144900	Fan Case - Front	1 Pc's	
M09	3611145000	Fan Case - Rear	1 Pc's	
M10	3612323200	Pipe Gasket	1 Pc's	
M10-a	7112401411	Screw-Self Tapping	3 Pc's	
M11	3619047900	THERMOSTAT FAN	1 Pc's	
M11-a	7121300811	Screw-Self Tapping	2 Pc's	
M12	361AAAAC20	Thermistor	1 Pc's	
M12-a	7122401411	Screw - Self Tapping	1 Pc's	
M13	3611886200	Fan Impeller	1 Pc's	
M14	3616039100	Lock Washer	1 Pc's	
M15	3616039200	Lock Nut	1 Pc's	
M16	3611428200	Fan Cover	1 Pc's	
M16-a	7122401411	Screw - Self Tapping	2 Pc's	

## 6. SUPPORT DRUM FRONT ASS'Y

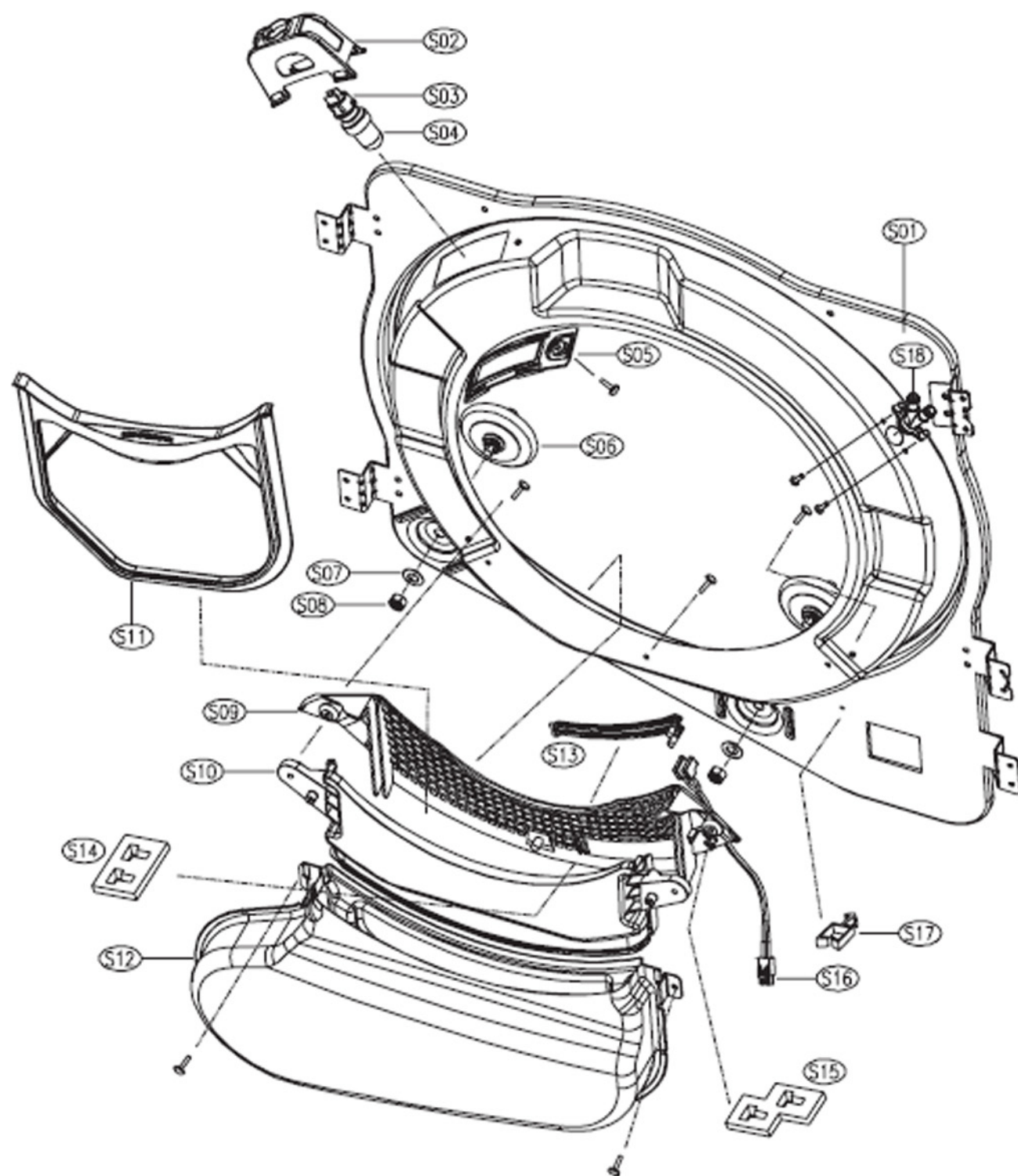

## Front ass'y dryer drum

ASKO, TLS752GXXL - Gas dryer #107752GPP (TLS752G)

Pos	Spare part No.	Description	Qty	Comment
S01	3615304600	Drum Support Front	1 Pc's	
S02	3613053400	Lamp Housing	1 Pc's	
S03	3613053300	Lamp Socket	1 Pc's	
S04	3613625400	LAMP	1 Pc's	
S05	3615505100	Lamp Cover	1 Pc's	
S05-a	7112401208	Screw-Self Tapping	1 Pc's	
S09	3611909700	Filter Body - Rear	1 Pc's	
S09-a	7122401408	SCREW TAPPING	3 Pc's	
S10	3611909600	Filter Body - Front	1 Pc's	
S10-a	7122401408	SCREW TAPPING	3 Pc's	
S11	3611909810	FILTER AS	1 Pc's	
S11-a	7122401408	SCREW TAPPING	3 Pc's	
S12	3617510400	Outlet Duct Assembly	1 Pc's	
S12-a	7122401408	SCREW TAPPING	3 Pc's	
S13	3614825500	Moisture Sensor	2 Pc's	
S14	3612009600	Sensor Bracket - Center	1 Pc's	
S15	3612009700	Sensor Bracket - Right	1 Pc's	
S16	3612797200	Harness - Sensor	1 Pc's	

# 10. CABINET FRONT ASS'Y

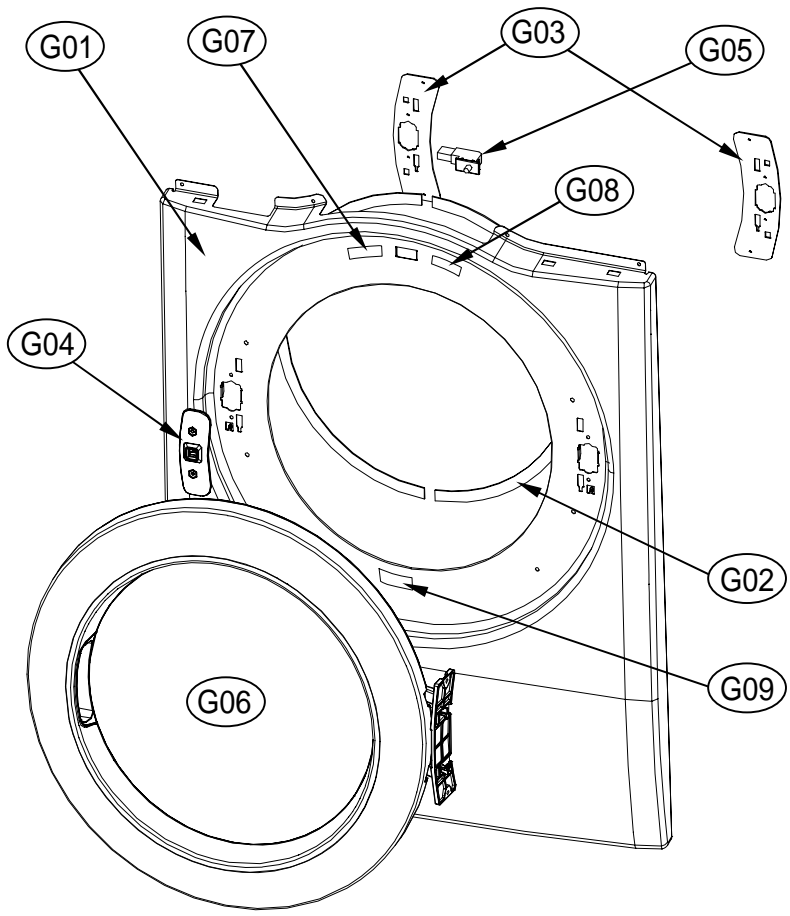



## **Cabinet Front**

**ASKO, TLS752GXXL - Gas dryer #107752GPP (TLS752G)**

<b>Pos</b>	<b>Spare part No.</b>	<b>Description</b>	<b>Qty</b>	<b>Comment</b>
G01	3610812500PPK	Front Panel PP w/labels	1 Pc's	
G02	3612323350	GASKET CABINET F	4 Pc's	
G03	3615304400	Hinge Support	2 Pc's	
G04	3613802500	Door Lock	1 Pc's	
G04-a	7002401608	Machine Screw	2 Pc's	
G05	3619047700	Door Switch	1 Pc's	
G06	36117ABQ00PP	DOOR AS	1 Pc's	
G07	3613558800	Warning Label	1 Pc's	
G08	3613557600	Caution Label	1 Pc's	
G09	3613558900	Rating Label	1 Pc's	

## 7. DRUM ASS'Y

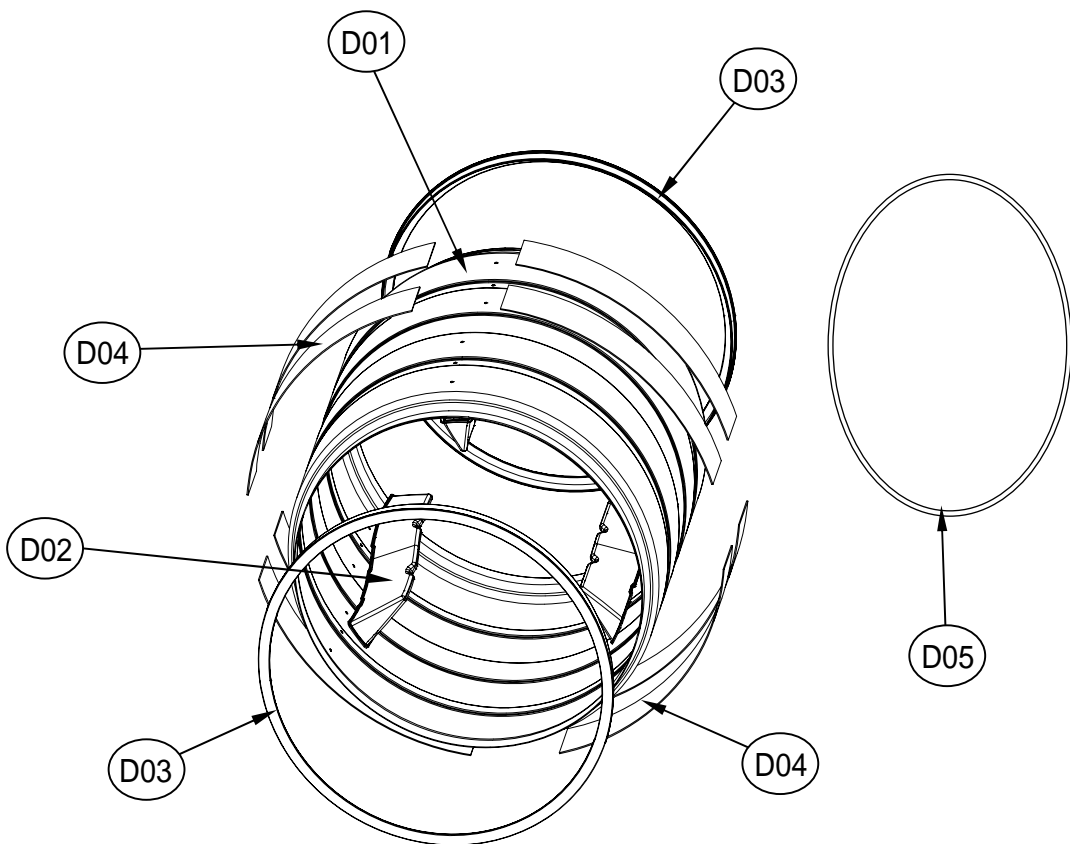

## **Drum Assembly**

**ASKO, TLS752GXXL - Gas dryer #107752GPP (TLS752G)**

<b>Pos</b>	<b>Spare part No.</b>	<b>Description</b>	<b>Qty</b>	<b>Comment</b>
D01	3617011000	DRUM	1 Pc's	
D02	361A401050	LIFTER	3 Pc's	
D02-a	7122502008	Screw-Self Tapping	12 Pc's	
D03	3614010600	Drum Seal	2 Pc's	
D04	3614111100	PAD DRUM	6 Pc's	
D05	3616591200	Belt	1 Pc's	

### 3. Gas Valve

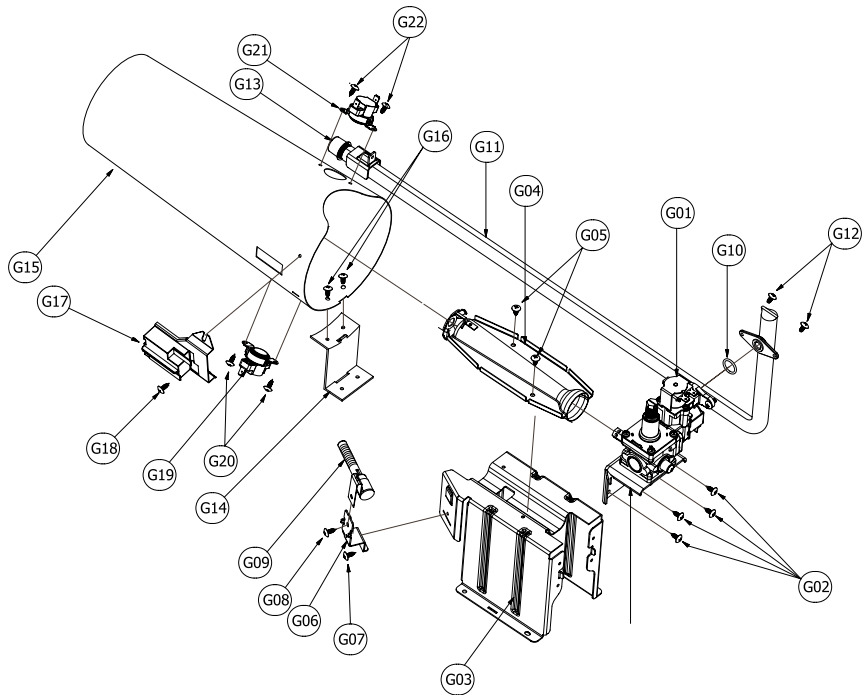

## Gas burner

ASKO, TLS752GXXL - Gas dryer #107752GPP (TLS752G)

Pos	Spare part No.	Description	Qty	Comment
G01	3615417300	Valve - LNG	1 Pc's	
G03	3612511100	Burner Guide	1 Pc's	
G04	3612209200	Mixing Venturi	1 Pc's	
G06	3610609400	Igniter Bracket	1 Pc's	
G09	36189L5800	Igniter	1 Pc's	
G10	3614604100	O-ring	1 Pc's	
G11	3614413800	Pipe Assembly	1 Pc's	
G13	3610918200	Pipe Cap	1 Pc's	
G14	3612009200	Funnel Fixture	1 Pc's	
G15	3612511300	Funnel	1 Pc's	
G17	3614825700	Flame Sensor	1 Pc's	
G19	3619047810	Thermostat Cut-Out	1 Pc's	
G21	3619047610	Saftey Thermostat - Non Re-set	1 Pc's	

## 4. HEATER DUCT ASS'Y

### 4-1. Electric Type

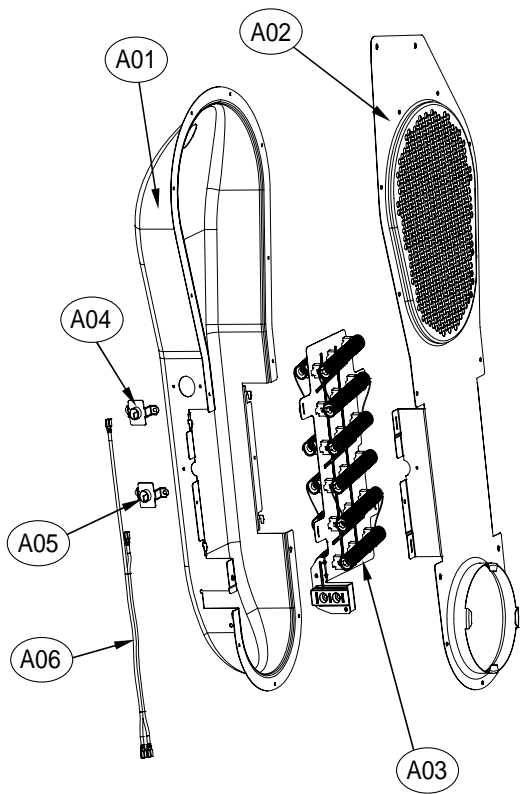

### 4-2. Gas Type

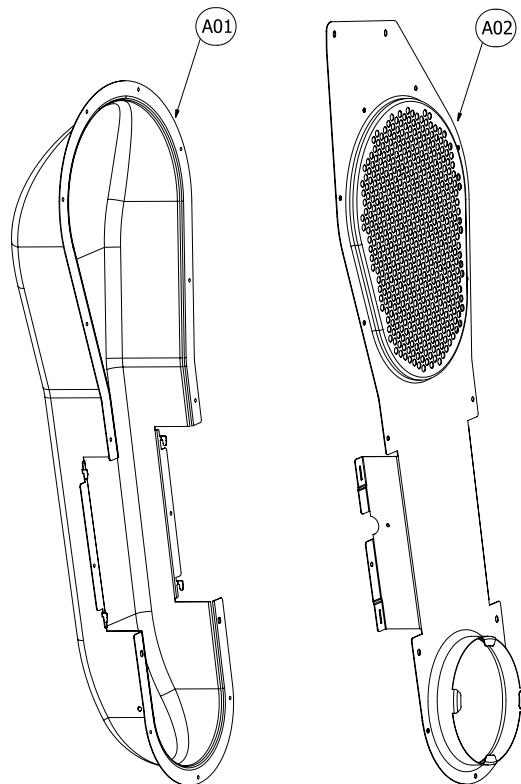

## **Rear Assembly Dryer**

*ASKO, TLS752GXXL - Gas dryer #107752GPP (TLS752G)*

<b>Pos</b>	<b>Spare part No.</b>	<b>Description</b>	<b>Qty</b>	<b>Comment</b>
A01	3617510210	DUCT INLET REAR GAS	1 Pc's	
A01-a	7122400811	Screw-Self Tapping	12 Pc's	
A02	3617510310	DUCT INLET FRONT GAS	1 Pc's	

# 11. PANEL F ASS'Y

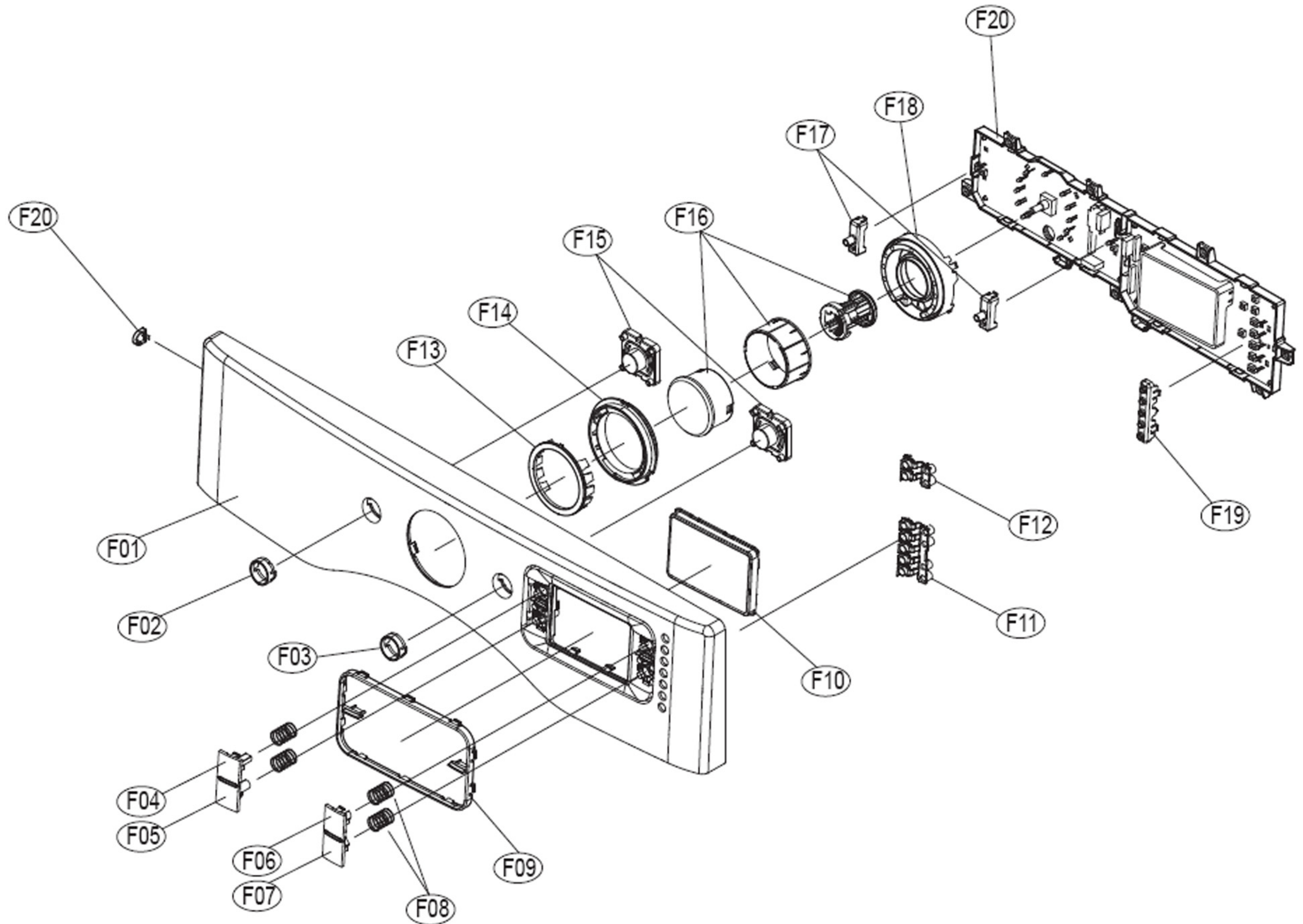



## Control Panel

### ASKO, TLS752GXXL - Gas dryer #107752GPP (TLS752G)

Pos	Spare part No.	Description	Qty	Comment
F01	3614289700PP	PANEL[U+x0096]F	1 Pc's	
F02	3611692110PP	DECO POWER	1 Pc's	
F03	3611692210PP	DECO START	1 Pc's	
F04	3616640700PP	BUTTON FUNCTION DRY LEVEL	1 Pc's	
F05	3616640800PP	BUTTON FUNCTION TEMP CONTROL	1 Pc's	
F06	3616640900PP	BUTTON FUNCTION TIME DRY	1 Pc's	
F07	3616641000PP	BUTTON FUNCTION BEEPER	1 Pc's	
F08	3615116200	SPRING BUTTON	4 Pc's	
F09	3611692410	DECO WINDOW	1 Pc's	
F10	3615508300	WINDOW DISPLAY	1 Pc's	
F11	3616641200PP	BUTTON OPTION	1 Pc's	
F12	3616641100PP	BUTTON TIME	1 Pc's	
F13	3615508200	WINDOW COURSE	1 Pc's	
F14	3611692310	DECO COURSE	1 Pc's	
F15	3616640500	BUTTON POWER	1 Pc's	
F16	3616640550	BUTTON AS	1 Pc's	
F17	3613056800	HOLDER POWER	2 Pc's	
F18	3613056900	HOLDER COURSE	1 Pc's	
F19	3613057000	HOLDER OPTION	1 Pc's	
F20	3611148800	CASE PCB F	1 Pc's	

## 2. GAS DRYER(ON/OFF CONTROL) WIRING DIAGRAMS

