

## Spare Parts Catalogue

ASKO Dishwashers \ ASKO 5000 XXL Series  
Type: DW70.3  
Model: D5233 XXL US Black Bi

Prod. No: 1075233122

April 24th 2012

**ASKO Appliances Inc.**

4001 E Plano Parkway #1004001 E Plano Parkway #100  
Plano, Texas 75074

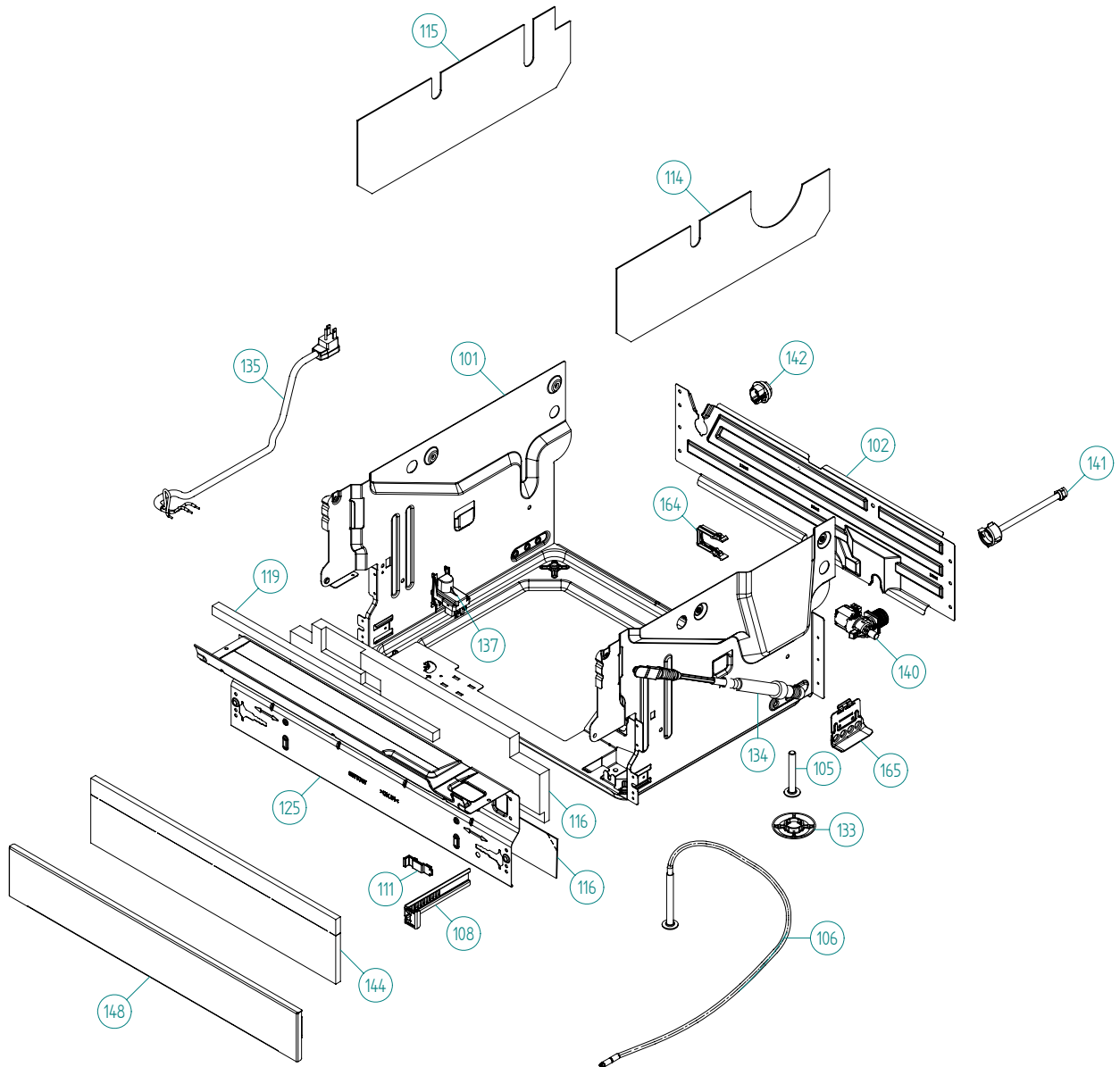

## Base and related parts

### ASKO, D5233 XXL US - Black Bi (DW70.3)

Pos	Spare part No.	Description	Qty	Comment
101	8801387	BOTTOM OUTER COMPL.	1 Pc's	
101-a	8901104	Screw 20 Torx Machine	2 Pc's	
101-b	8901110	Screw w/ORing DW 05/06 25T	4 Pc's	
102	8078006	REAR PANEL	1 Pc's	
105	8074228	Leveling Foot M10X75 T30 8.8 FZB	2 Pc's	
106	8082222	FOOT ADJUSTABLE FROM FRONT CPL	1 Pc's	
108	8073480	Toe Kick bracket Right & Left	2 Pc's	
111	8073481-49	Toe Kick Bracket Clip L-Grey	2 Pc's	
114	8078109	SOUND ABSORP. SELF AD. RIGHT	1 Pc's	
115	8078108	SOUND ABSORP. SELF AD. LEFT	1 Pc's	
116	8078114	SOUND ABSORBENT GUARD PLATE	1 Pc's	
116	8082272	Sound Absorb Protective Plate	1 Pc's	
119	8078122	SOUND ABSORPTION PROFILE	1 Pc's	
125	8078008-29	GUARD PLATE STRAIGHT BLACK	1 Pc's	
133	8051957	Glide Foot	3 Pc's	
134	8079528	Door Spring-DW70-Yellow	1 Pc's	
134	8079529	Door Spring-DW70-Red	1 Pc's	
135	8079046	CORD SET AMERICA	1 Pc's	
135	8083262	CORD SET 15A AMERICA	1 Pc's	
137	8083041	Terminal Block w/RFI DW70	1 Pc's	
137-a	8901097	Screw Terminal	1 Pc's	
140	8801376	KIT INL.VALVE/LOCKARM SING120V	1 Pc's	
140-a	8079597	LOCK ARM INLET VALVE	1 Pc's	
141	8079522	PEX Inlet hose DW	1 Pc's	
142	8006948	Grommet	1 Pc's	
144	8074585	Felt Kick Plate 05	1 Pc's	
148	8073506-29	KICK-PLATE USA XXL BLACK	1 Pc's	
162	8079832	CABLE HOLDER SRC-8-01	1 Pc's	
164	8079597	LOCK ARM INLET VALVE	1 Pc's	
165	8078013	DOOR SPRING HOLDER	1 Pc's	
165-a	8902362	SCREW RTK ST 4,2X9,5 FZB WAX.	1 Pc's	

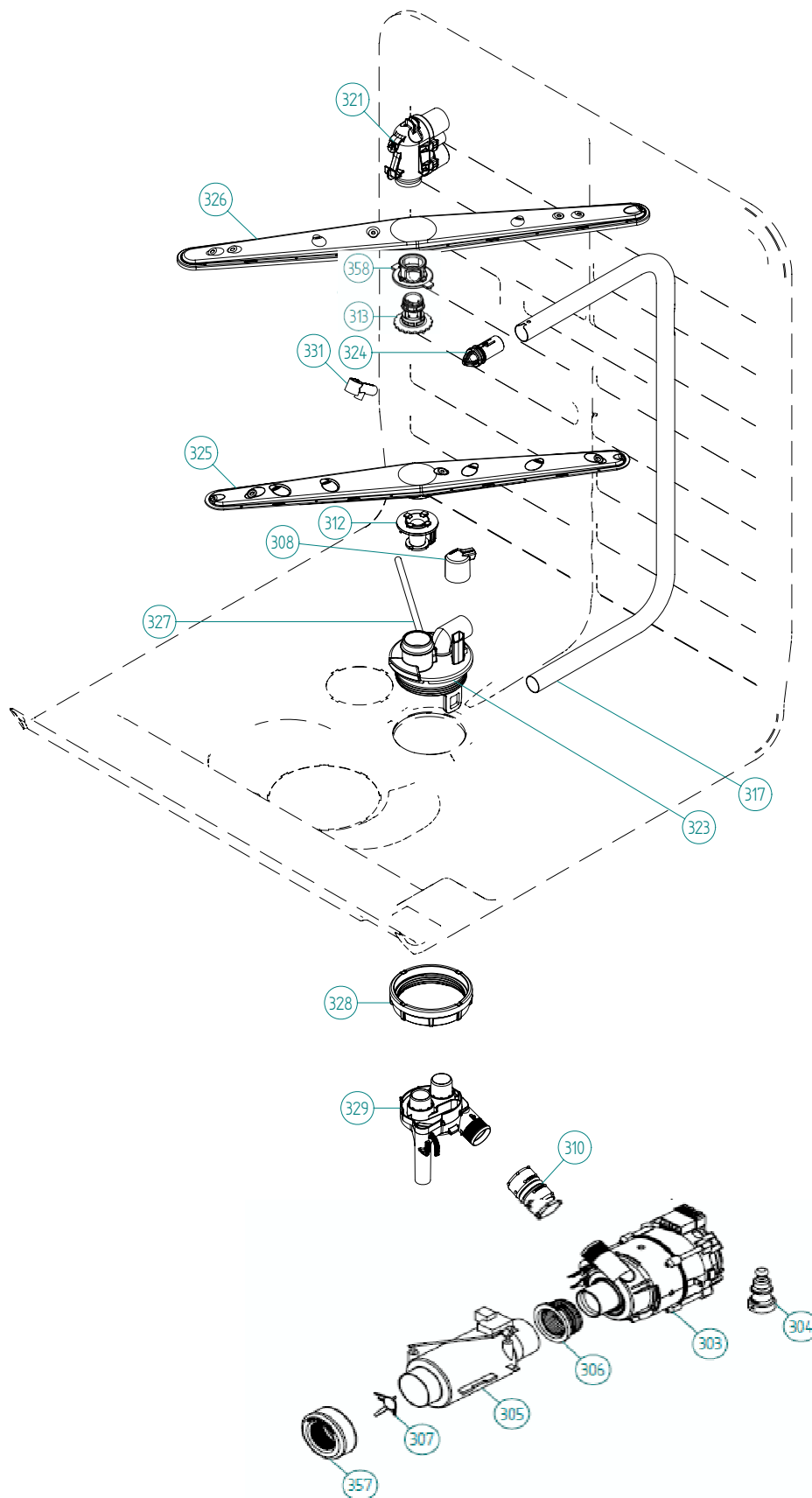

## Wash System

### ASKO, D5233 XXL US - Black Bi (DW70.3)

Pos	Spare part No.	Description	Qty	Comment
301	8078001	-	1 Pc's	Not a spare part
303	8078082	CIRC.PUMP 120V 60HZ	1 Pc's	
303-a	8083804	Capacitor 7 0UF 400V P2 CLASS	1 Pc's	
304	8075130	Rubber Damper Circ Pump	1 Pc's	
305	8801463	HEATER W.INSERT 1200W120V DW70	1 Pc's	
306	8079531	SEALING HEATER DW70 UL4	2 Pc's	Only 1 pc from 2009-06-11
307	8079575	INSERT FOR HEATER	1 Pc's	
308	8073385-77	Cup Drainage Gray	1 Pc's	
310	8801409	Hose Circ Pump	1 Pc's	
310-a	8056491	HOSE CLIP 30.1-708	2 Pc's	
312	8801270	Spray Arm Bearing Kit	1 Pc's	
313	8079108-77	SPRAYARM BEARING H&L U.BASKET	1 Pc's	
317	8079112-E	SPRAYTUBE ADJ.U-BASKET XXL	1 Pc's	
321	8801359	SPRAYTOWER COMPL H&L BASKET	1 Pc's	
323	8801270	KIT SPRAYARM BEAR. LOW NOZZLE	1 Pc's	
323-a	8901765	ORing det Comp 03/04 DW	1 Pc's	
324	8079113-77	GUIDE SPRAYTUBE ADJ BASKET	1 Pc's	
325	8072891	Spray Arm Lower Complete	1 Pc's	
326	8079111	SPRAYARM CPL H&L BASKET	1 Pc's	
327	8073381	Tube Pot Rinse	1 Pc's	
327-a	8902085	Screw 20T for Plastic	2 Pc's	
328	8071607	Locking Spray Pipe Bearing	1 Pc's	
329	8078086	INTERMEDIATE	1 Pc's	
331	8072543-77	Spray Nozzle	1 Pc's	For part no 8073381 and 8076902-L-77
357	8083603	SEALING HEATER BOTTOM SUMP	1 Pc's	
358	8079261-77	INSERT SPRAYARM BEAR.H&L BASK.	1 Pc's	

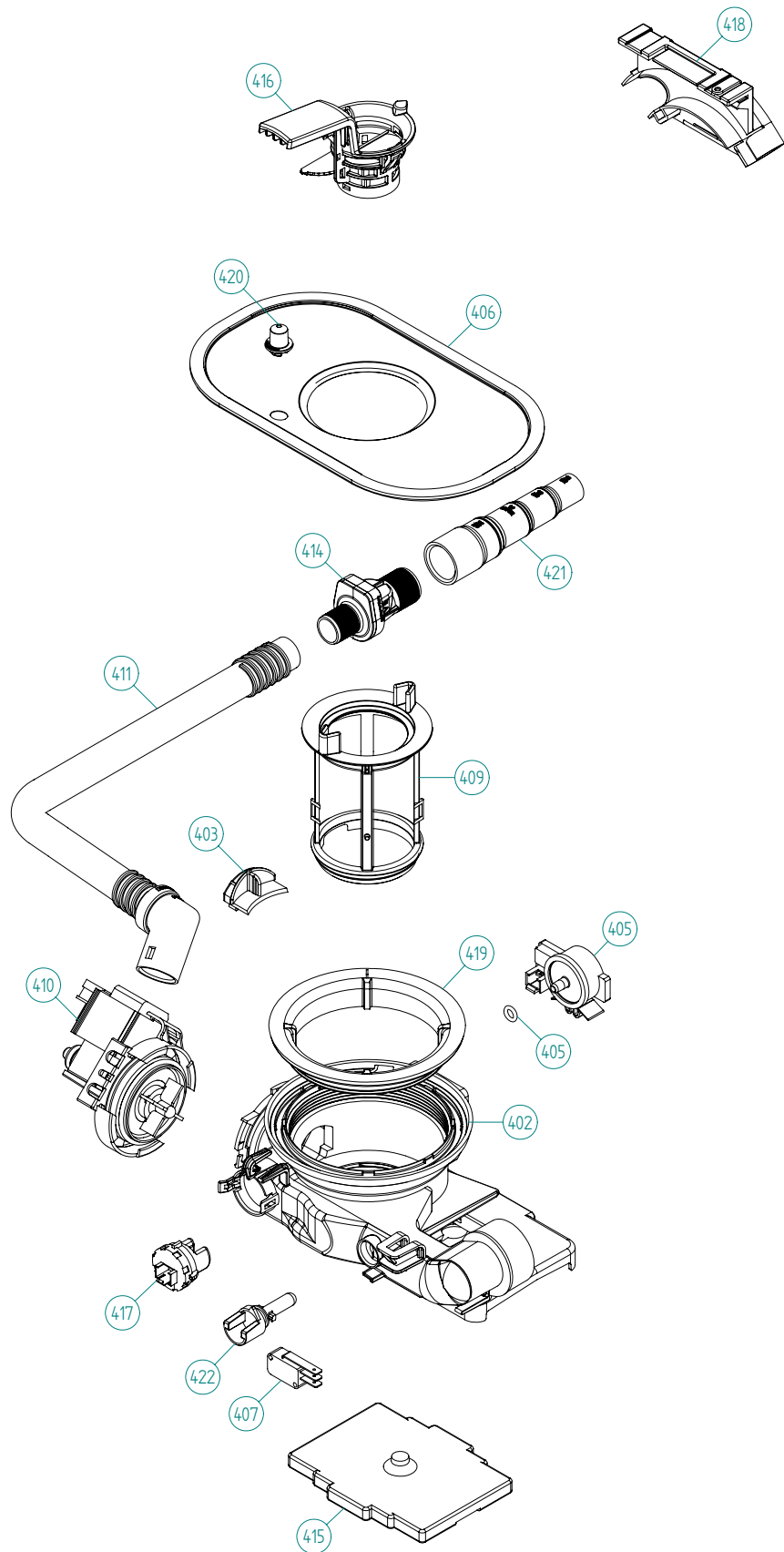

## **Bottom well and related parts**

### **ASKO, D5233 XXL US - Black Bi (DW70.3)**

<b>Pos</b>	<b>Spare part No.</b>	<b>Description</b>	<b>Qty</b>	<b>Comment</b>
402	8084692	BOTTOM WELL 2 SENSOR UL4	1 Pc's	
402	8801452	KIT BOTTOM W.NO RET.VALVE 2SEN	1 Pc's	
402-a	8073002	ORing	1 Pc's	
403	8078033	Rinse Cap Bottom Well - Yellow	1 Pc's	
405	8073839	Pressure Sensor	1 Pc's	
405-a	8074040	O-Ring-Press Sensor	1 Pc's	
406	8074364	Strainer DW20	1 Pc's	
407	8073835	Microswitch Float	1 Pc's	
409	8078038-77	Pipe Filter DW70	1 Pc's	
410	8078089	Drain Pump 120V 60Hz	1 Pc's	
411	8079693	Outlet Hose w/o Return Valve	1 Pc's	
411	8083478	OUTLET HOSE HARD END CUFF US	1 Pc's	
411-a	8901768	O-RING 32,3X3 (BD)	1 Pc's	
414	8801248	Check Valve Kit	1 Pc's	
414-a	8052239	Hose Clamp	1 Pc's	
414-b	8053642	Hose Clamp	1 Pc's	
415	8078025	Float	1 Pc's	
416	8078039-77	Strainer Basket Grey	1 Pc's	
417	8081321	TURBIDITY SENSOR DW20/70	1 Pc's	
418	8072528-77	Holder Outlet Hose	1 Pc's	
418-a	8053642	Hose Clamp	1 Pc's	
418-b	8052239	Hose Clamp	1 Pc's	
418-c	33700450	Cable Strip	1 Pc's	
418-d	8902072	SCREW PT KB40X10 WN1442 GALV	1 Pc's	
419	8072848	Lockring Bottom Well	1 Pc's	
420	8074760-77	Ventilator	1 Pc's	
421	8075321	End Cuff	1 Pc's	
422	8078096	Thermistor	1 Pc's	
426	8078024	SEALING NON RETURN VALVE	1 Pc's	
427	8901768	O-RING 32,3X3 (BD)	1 Pc's	

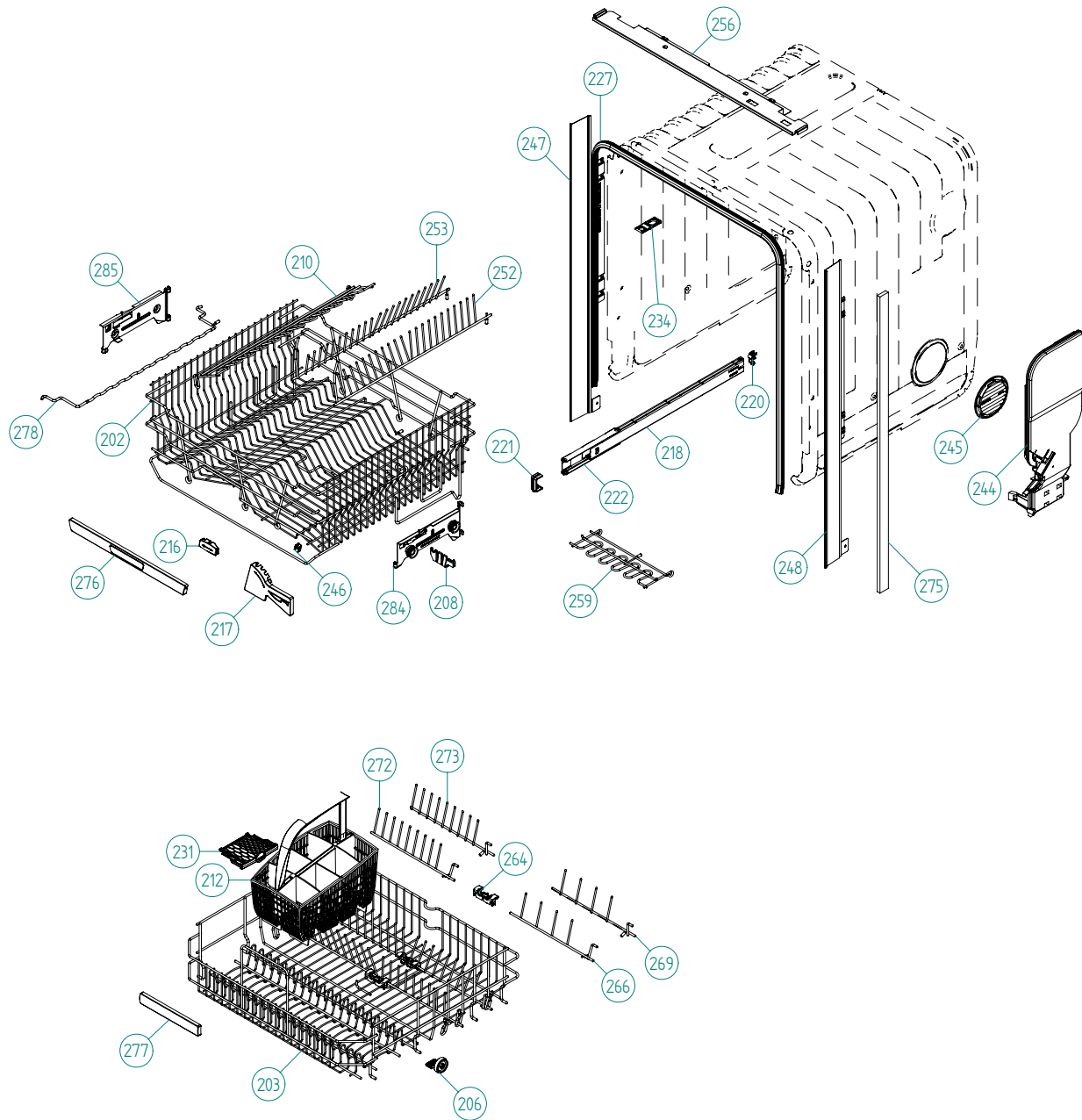



## Baskets and related parts

### ASKO, D5233 XXL US - Black Bi (DW70.3)

Pos	Spare part No.	Description	Qty	Comment
201	8057056	-	1 Pc's	Not a spare part
202	8801358-36	UPPER BASKET EXCL. COMPL. H&L	1 Pc's	
203	8801316-36	LOWER BASKET EXCL D.GREY 07	1 Pc's	New design
206	8079257-77	WHEEL FOR LOW DISHW BASKET CPL	8 Pc's	
208	8071214-77	Knife Holder 05/06 DW	2 Pc's	
210	8071337-36	Cup Shelf Wine Glass 05/06 DW	1 Pc's	
212	8801396-77	Cutlery Bskt for Stnd Tines	1 Pc's	
216	8072553-77	BRACKET PIN ROW UPPER BASKET	1 Pc's	
217	8072554-77	KNIFE GUARD	1 Pc's	
218	8801350	DW Upper Basket Guide Rail Kit	2 Pc's	
220	8057978-77	DW Rail Stop - Back Grey	2 Pc's	
221	8088703-77	BASKET STOP	2 Pc's	
222	8801349-77	KIT BALL HOLDER INCL. BALLS	1 Pc's	
225	8057978-77	DW Rail Stop - Back Grey	2 Pc's	
227	8057489-F	DOOR STRIP XXL DW70	1 Pc's	
231	8079251-77	DOOR CUTLERYBASKET UL4	1 Pc's	
234	8070649	Lock Hitch Int	1 Pc's	
234-a	8070654	Lock Washer Int	1 Pc's	
234-b	8901104	Screw 20 Torx Machine	1 Pc's	
244	8078300	AIRBREAK STD. DW70 UL4	1 Pc's	
245	8057536-77	LOCKRING AIREBREAKER GREY	1 Pc's	
246	8075350	Clip for Knife Guard	1 Pc's	
247	8074342-E-29	Trim Strip Left XXL Blk	1 Pc's	
247-a	8900646	Screw 20 Torx SS	2 Pc's	
248	8074343-E-29	Trim Strip Right XXL Blk	1 Pc's	
248-a	8900646	Screw 20 Torx SS	2 Pc's	
252	8072552-36	PLATERACK RIGHT U-BASKET	1 Pc's	
253	8072551-36	PLATERACK LEFT U-BASKET	1 Pc's	
256	8075663-29	Top Trim Rail Low Black	1 Pc's	
259	8076619-36	wine glass cup shelf divider	2 Pc's	
264	8076632-77	Holder	3 Pc's	
266	8079130-36	PlateRack short/wide R-FT	1 Pc's	
269	8079131-36	PlateRack short/wide R-BK	1 Pc's	
272	8079123-36	PlateRack short/narrow L-FT	1 Pc's	
273	8079124-36	PlateRack short/narrow L-BK	1 Pc's	
275	8070614	SEALING STRIPE TRIM STRIPE USA	2 Pc's	
276	8801330-77	HANDLE U-BASKET COMPL. ASKO	1 Pc's	
277	8801332-77	HANDLE LOWER BASKET COMPL.	1 Pc's	
278	8072764-36	GLASS SUPPORT D-GREY	1 Pc's	
278	8079144-36	GLASS SUPPORT D-GREY	1 Pc's	
284	8079138	Basket Adj Bracket Right	1 Pc's	
285	8079139	Basket Adj Bracket Left	1 Pc's	

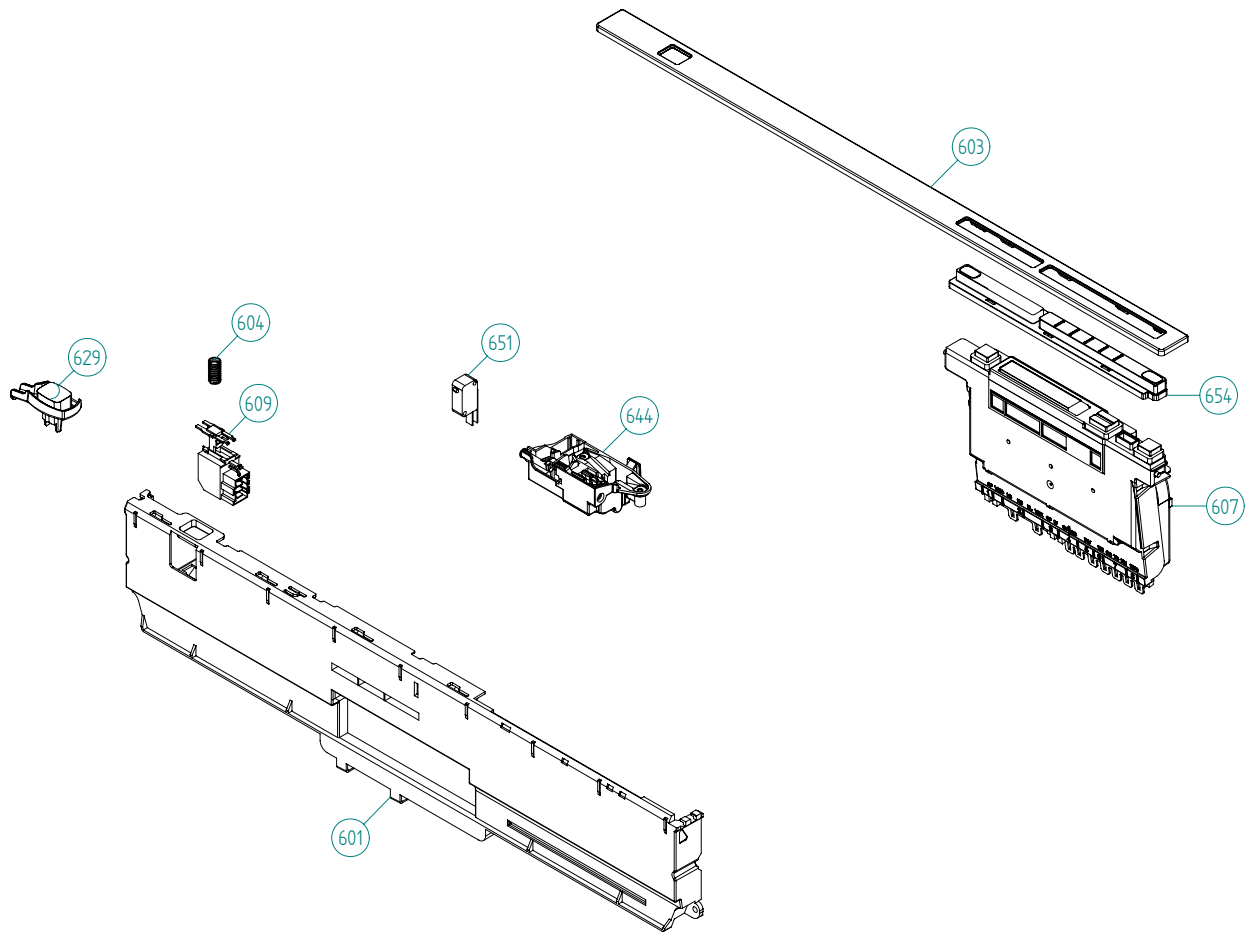

## Control panel and related parts

### ASKO, D5233 XXL US - Black Bi (DW70.3)

Pos	Spare part No.	Description	Qty	Comment
601	8084001-UL	PANEL DW90 INTEGRATED LOCK UL4	1 Pc's	
602	8082884	PROG.INFO.LABEL 3KN AUT/DEL US	1 Pc's	
603	8082879-69	CONTROL LENS ASKO D5233 (70.3)	1 Pc's	
604	8074277	SPRING MAIN SWITCH	1 Pc's	
607	8801435	CONT.UNIT DW70.3 INTERVAL FAN	1 Pc's	
609	8073782	MAIN PUSH SWITCH	1 Pc's	
610	8079517	CABLE SET THERMISTOR UL4	1 Pc's	
614	8078068	CABLE SET CI.PUMP IN.VALVE UL4	1 Pc's	
616	8078064	CABLE SET FLOW PRESS. TURB.UL4	1 Pc's	
618	8078070	CABLE SET POWER UL4	1 Pc's	
620	8075730	Cable Set Fan	1 Pc's	
622	8078063	CABLE SET DRAIN UL4	1 Pc's	
629	8081633-69	PUSHB. MAINSW. DW70.3 GRAP UL4	1 Pc's	
644	8073670	Lock Complete Integrated	1 Pc's	
651	8073836	MICROSWITCH DOOR	0 Pc's	
654	8082880-85	PUSH BUTTONS ASKO 70.3 3KN GR.	1 Pc's	

# D5233 XXL US

# Inner door, panel and related parts

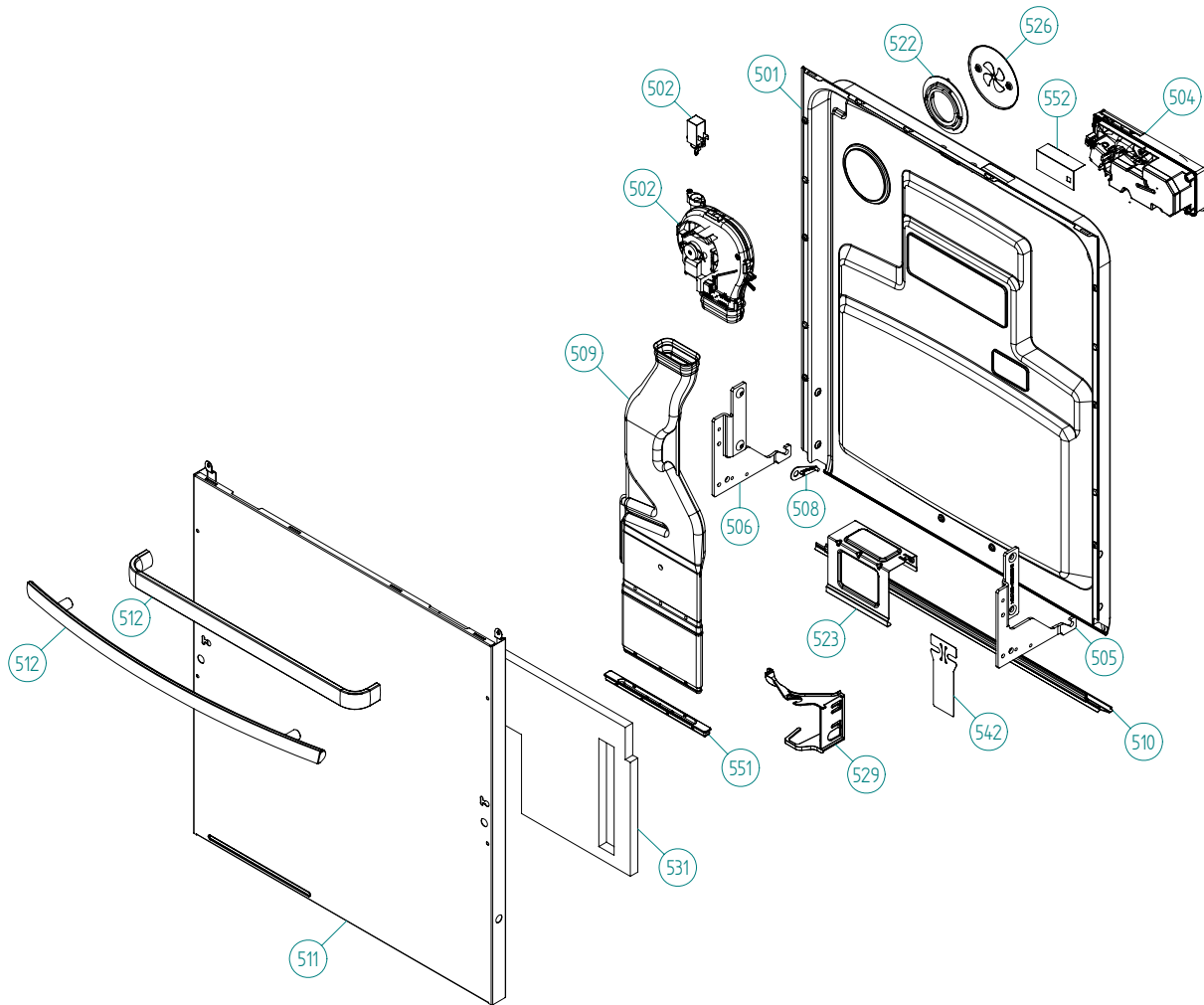

## Inner door, panel and related parts

### ASKO, D5233 XXL US - Black Bi (DW70.3)

Pos	Spare part No.	Description	Qty	Comment
501	8801380	Door Inner w/Fan XXL DW70	1 Pc's	
501-a	8900646	Screw 20 Torx SS	6 Pc's	
501-b	8902121	SCREW A2-MKFT 5X10	4 Pc's	
502	8089580	Fan Complete 120V	1 Pc's	
502-a	8058501	ORing Turbo Fan Dry 05/06 DW	1 Pc's	
502-b	8801438	KIT WITH NEW WAXMOTOR DW	1 Pc's	
504	8801343-77	KIT Combi Dispenser 120V	1 Pc's	
504-a	8071918	Seal Det Comp Lid	1 Pc's	
504-b	8071917	CAP RINSE AGENT	1 Pc's	
504-c	8071918	Detergent Lid Complete	1 Pc's	
504-d	8072288	Sealing Strip Combi Disp.	1 Pc's	
504-f	8902087	Screw Plastic Housing 20 Torx	6 Pc's	
505	8801458	HINGE RIGHT COMPL. DW70	1 Pc's	
506	8801459	HINGE LEFT COMPL. DW70	1 Pc's	
507	8057530	Screw hinge 05	2 Pc's	
507-a	33500262	Nut Term Block	2 Pc's	
508	Repl by 8801458 & 8801459	Slide washer hinge bearing 05	2 Pc's	
509	8078040	Air Channel DW70	1 Pc's	
510	8801294	DOOR SEAL LOWER W.CORNER GUARD	1 Pc's	
511	8078019-K	Outer Door for Tbar Hndl	1 Pc's	
511	8078019-X	Outer Door for Sense Hndl	1 Pc's	
511	8078019-X-29	Outer Door for Sense Hndl - BLK	1 Pc's	
511-a	8900646	Screw 20 Torx SS	6 Pc's	
512	8083321	HANDLE SENSE 510 ASKO	1 Pc's	
512	8083044	HANDLE SENSE 450 ASKO	1 Pc's	
522	8089401	LOCKKING RING 2 FAN HOUSE UL4	1 Pc's	
522-a	8902085	Screw 20T for Plastic	2 Pc's	
523	8057983	Brace	1 Pc's	
523-a	8900646	Screw 20 Torx SS	2 Pc's	
523-b	8902357	Screw	2 Pc's	
526	8058484	SS Coverplate Turbo Fan DW	1 Pc's	
526-a	8902085	Screw 20T for Plastic	2 Pc's	
529	8074278	Bracket for harness	1 Pc's	
531	8074258	Sound Absorbtion Outer Door	1 Pc's	
542	8076966	COVER, CABLES	1 Pc's	
551	8079584-33	Air Channel Nozzle DW70	1 Pc's	
552	8083021	COVER COMBI DISPENSER	1 Pc's	

- CD: COMBI DISPENSER
  - CP: CIRCULATION PUMP
  - DIV: WATER DIVERTER VALVE
  - DP: DRAIN PUMP
  - DR: DOOR
  - DS: DOOR SWITCH
  - F: FILTER
  - FM: FLOW METER
  - FN 1: FAN DOOR
  - FN 2: FAN BOTTOM
  - FS: FLOAT SWITCH
  - HE: HEATING ELEMENT
  - HE (PTC): HEATING ELEMENT PTC
  - HL: HALOGEN LAMP
  - HS: HUMIDITY SENSOR
  - IS: ILLUM. SWITCH
  - IV: INLET VALVE
  - I2C: I2C
  - MS: MAIN SWITCH
  - MV: MIX VALVE
  - PS: PRESSURE SENSOR
  - RAS: RINSE AID SENSOR
  - SL: STATUS LIGHT
  - SS: SALT SENSOR
  - SV: SALT VALVE
  - TH: THERMISTOR
  - TS: TURBIDITY SENSOR
  - UART: UART
  - VAX: VAX ACTUATOR
- WIRES IN ALL MACHINES  
 - - - INTERNAL CONNECTION  
 - · - WIRES IN SOME MACHINES

**RESISTANCES AT ROOM TEMPERATURE (CA. 20°C/68°F)**  
**VALUES WITH +/-10% ARE REGARDED AS NORMAL**

COMPONENT	RESISTANCE
RADIO INTERFERENCE SUPPRESSION FILTER	1 MOHM
HEATING ELEMENT 1200W 120V	12 OHM
HEATING ELEMENT 1600W 230V	32 OHM
HEATING ELEMENT 2040W 230V	25 OHM
THERMISTOR	25 KOHM
COMBINED DISPENSER 120V	0.3 KOHM
COMBINED DISPENSER 230V	1,6 KOHM
CIRCULATION PUMP 120V 60HZ	32 OHM
CIRCULATION PUMP 230V 50HZ	110 OHM
CIRCULATION PUMP 220V 60HZ	56 OHM
DRAIN PUMP 120V 60HZ	25 OHM
DRAIN PUMP 230V 50HZ	150 OHM
DRAIN PUMP 230V 60HZ	85 OHM
SPRAY ARM DIVIDER 120V 60HZ	2.6 KOHM
SPRAY ARM DIVIDER 230V 50/60HZ	8,5 KOHM
INLET VALVE SINGLE INCL. 120V	0.95 KOHM
INLET VALVE SAFETY INCL. 120V	0.5 KOHM
INLET VALVE SINGLE INCL. 230V	3,9 KOHM
INLET VALVE SAFETY INCL. 230V	2 KOHM
SALT VALVE 120V	0,65 KOHM
MIX VALVE 120V	0,65 KOHM
SALT VALVE 230V	3 KOHM
MIX VALVE 230V	2,3 KOHM
HALOGEN LAMP 5W 12V	<10 KOHM
WAX MOTOR	1.1 KOHM
FAN MOTOR 120V	0.18 KOHM
FAN MOTOR 230V	0,85 KOHM

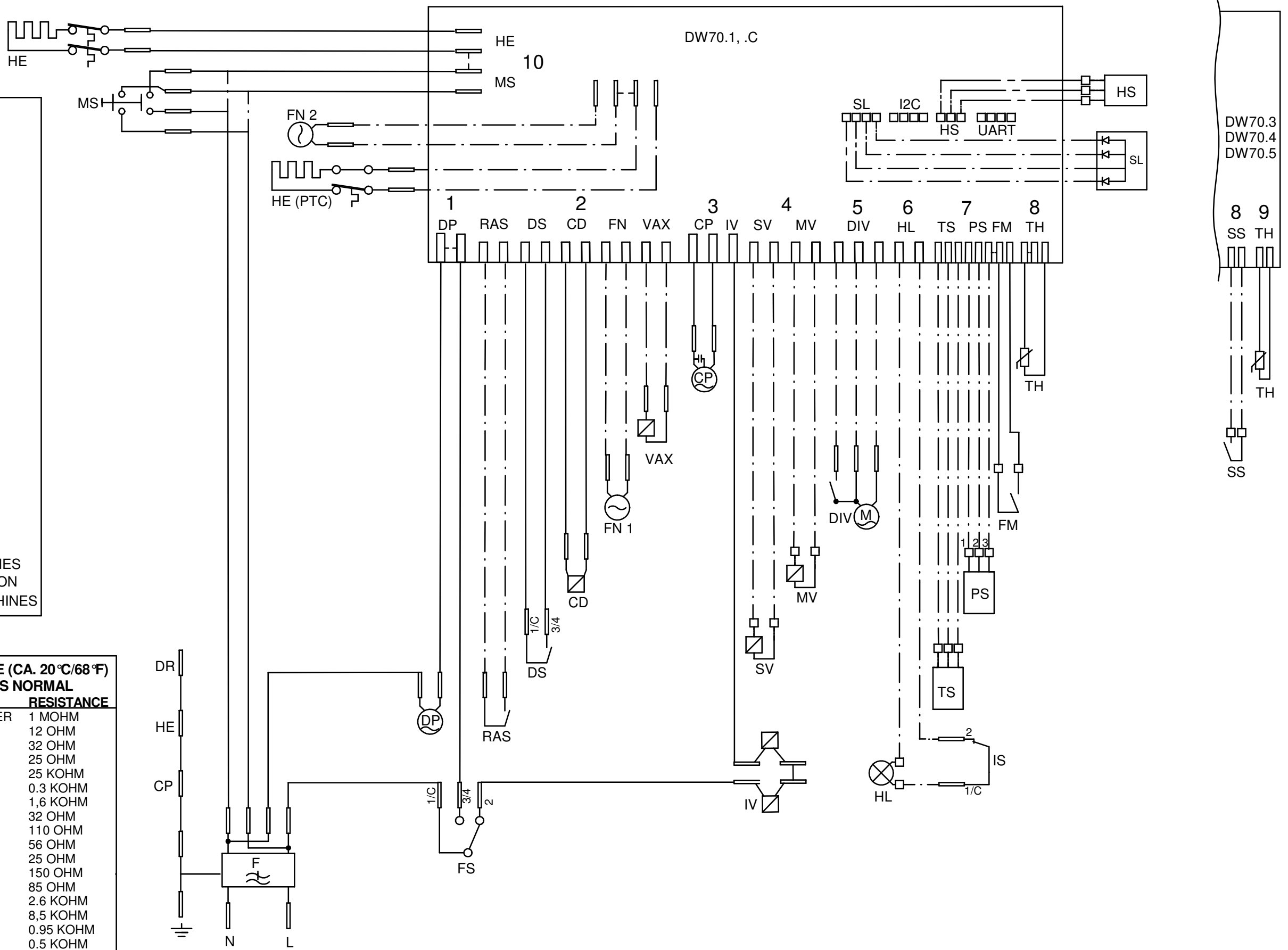

CIRCUIT DIAGRAM DW70.1, .3, .4, .5, .C  
**80 796 55 - 01**

This document must not be copied without our written permission, and the contents thereof must not be imparted to a third party nor be used for any unauthorized purpose. Contravention will be prosecuted. Asko Appliances AB

## Displays

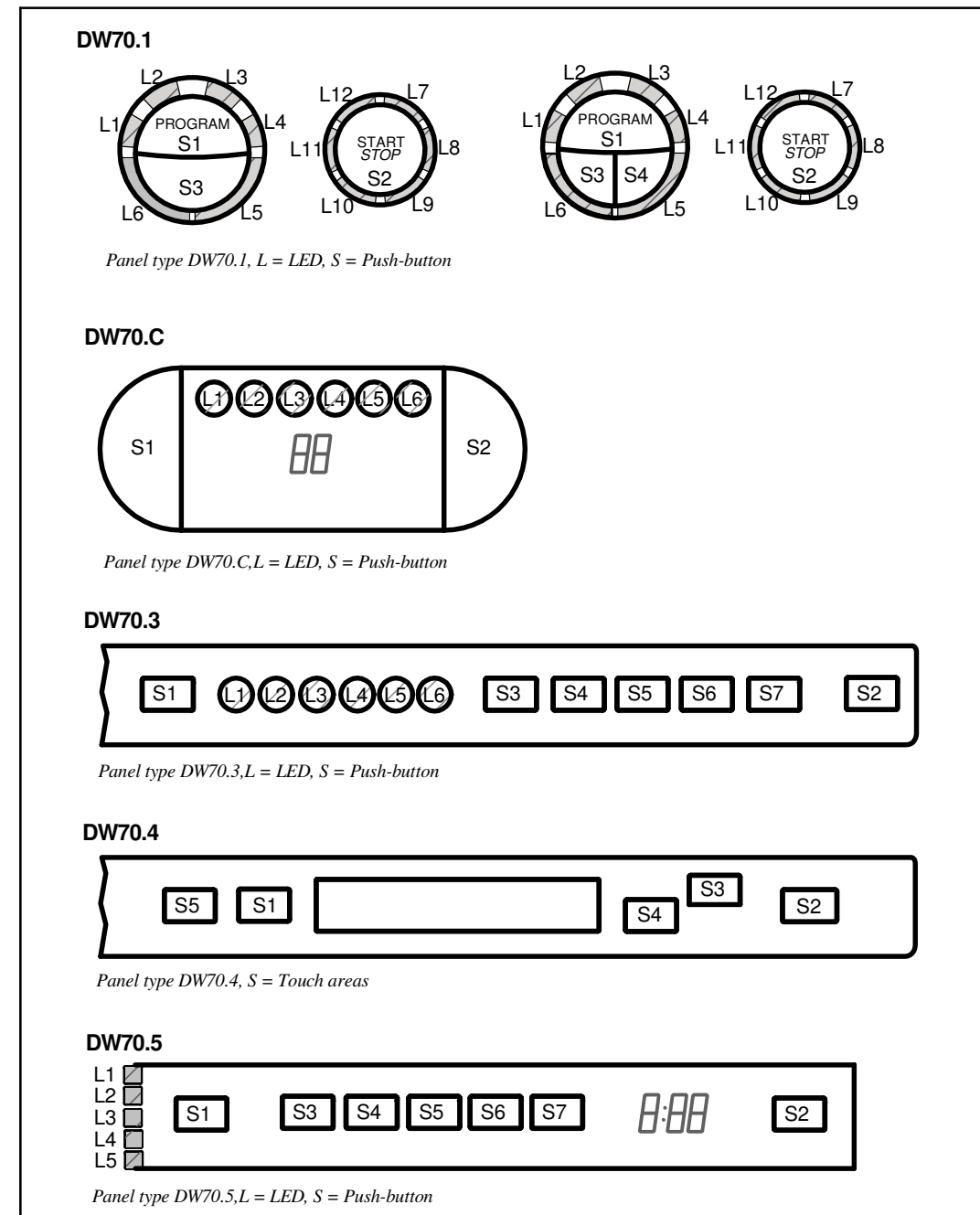

### TOTAL RESET

TURN OFF MAIN SWITCH  
 WAIT FOR AT LEAST 5 SECS  
 HOLD PROGRAM BUTTON (S1), FOR DW70.4 HOLD PROGRAM BUTTON (S1)  
 AND NAVIGATION BUTTON (S4).  
 TURN ON MAIN SWITCH  
 RELEASE PROGRAM BUTTON (S1), FOR DW70.4 RELEASE PROGRAM BUTTON (S1)  
 AND NAVIGATION BUTTON (S4).

### SERVICE MENU

TURN OFF MAIN SWITCH  
 WAIT FOR AT LEAST 5 SECS  
 HOLD PROGRAM AND START BUTTONS (S1 & S2)  
 TURN ON MAIN SWITCH  
 RELEASE PROGRAM AND START BUTTONS (S1 & S2)

### VARIANT SETTING (NOT DW70.4)

HOLD PROGRAM AND START BUTTONS (S1 & S2)  
 TURN ON MAIN SWITCH  
 RELEASE PROGRAM AND START BUTTONS  
 PRESS START (S2) 3 TIMES WITHIN 5 SECS  
 SELECT VARIANT BY START BUTTON (S1) AND  
 CONFIRM BY START BUTTON (S2)

## COMPONENT TEST:

**First enter Service menu.**

### DW70.1, DW70.3, DW70.5 and DW70.C

Component test:

Press the Program button (S1) and index through the following components:

1. Inlet valve and mix valve (only machines with water softener)
2. Inlet valve
3. Salt valve (only machines with water softener)
4. Detergent and surfactant dispenser
5. Circulation pump
6. Heating element and circulation pump (Max 75°C)
7. Fans
8. Drain pump

### DW70.4

**First enter service menu.**

Go to service menu step 2, Diagnostics, by pressing S4

Press (S3) to activate the following components:

1. Valve (Inlet valve and mix valve (only machines with water softener), display flowsensor value)
2. Valve (Inlet valve, display flowsensor value)
3. Salt (Salt valve, only machines with water softener)
4. Disp (Detergent and surfactant dispenser)
5. Circ (Circulation pump, display shows turbidity in Volts)
6. Heat (Heating element and circulation pump (Max 75°C))
7. Fans (display shows humidity sensor value)
8. Drain (Drain pump, display shows pressure sensor reading; 0.5-3.5 VDC)

CIRCUIT DIAGRAM DW70.1, .3, .4, .5, .C

80 796 55 - 01

This document must not be copied without our written permission, and the contents thereof must not be imparted to a third party nor be used for any unauthorized purpose. Contravention will be prosecuted. Asko Appliances AB

## Displayer

### DW70.1

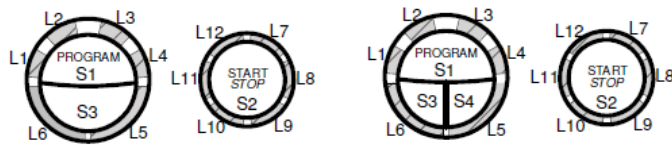

Paneltyp DW70.1, L=LED, S= Tryckknapp

### DW70.C

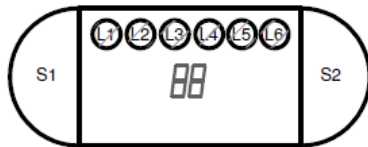

Paneltyp DW70.C, L=LED, S= Tryckknapp

### DW70.3



Paneltyp DW70.3 L=LED, S= Tryckknapp

### DW70.4

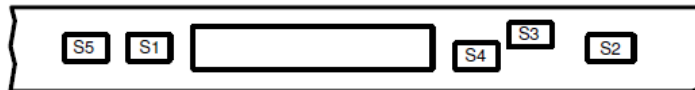

Paneltyp DW70.4, S = Tryckområde

### DW70.5

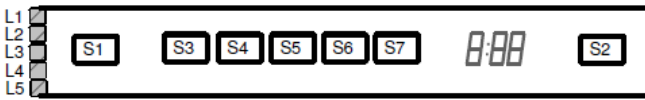

Paneltyp DW70.5 L=LED, S= Tryckknapp

## Återställning

- Stäng av huvudströmbrytaren.
- Vänta i åtminstone 5 sekunder.
- Håll nere programknappen (S1) (för DW70.4 håll nere programknappen (S1) och navigationsknappen (S4)).
- Slå på huvudströmbrytaren (S1).
- Släpp programknappen (S1) (för DW70.4, släpp programknappen (S1) och navigationsknappen (S4)).

## Servicemeny

- Stäng av huvudströmbrytaren.
- Vänta i åtminstone 5 sekunder.
- Håll program- och startknappen (S1 & S2) intryckta.
- Slå på huvudströmbrytaren.
- Släpp program- och startknappen (S1 & S2).

## Variantinställning (ej DW70.4)

- Håll program- och startknapp (S1 & S2) intryckta.
- Slå på huvudströmbrytaren
- Släpp program- och startknapparna (S1 & S2)
- Tryck på startknappen (S2) 3 gånger inom 5 sekunder.
- Välj variant genom att trycka på startknappen (S2) och bekräfta ditt val genom att trycka på programknappen (S1)

## Komponenttest:

Gå först in i Servicemenyn.

### DW70.1, DW70.3, DW70.5 och DW70.C

Komponenttest:

Tryck på knappen (S1) och stega igenom följande komponenter:

1. Inloppsventil och mixventil (endast maskiner med avhårdare)
2. Inloppsventil
3. Saltventil (endast maskiner med avhårdare)
4. Diskmedel och sköljmedelsdoserare
5. Cirkulationspump
6. Värmeelement och cirkulationspump (Max 75°C)
7. Fläktar
8. Avloppspump

### DW70.4

Gå först in i servicemenyn.

Gå först till servicemenyn steg 2 genom att trycka på knappen (S4)

Tryck på knappen (S3) för att aktivera följande komponenter:

1. Ventil (Inloppsventil och mixventil (endast maskiner med avhårdare) display visar intagen vattenmängd i antal pulser; pulsmätare är placerad i luftavbrottet).
2. Ventil (Inloppsventil, visar trycksensorvärde)
3. Salt (Saltventil, endast maskiner med avhårdare)
4. Behållare (Disk- och vätmedelsdoserare)
5. Cirkulation (Cirkulationspump)
6. Värme (Värmeelement och cirkulationspump (Max 75 °C))
7. Fläktar (Displayen visar fuktensorvärde)
8. Avloppspump