

PIEGHE IN GIU'
PIEGHE IN SU'

This drawing contains confidential information and is the property of ILVE SPA. without whose permission it may not be copied, shown or handed to a third party or otherwise used, and it is to be returned promptly upon request to the ILVE SPA, which is responsible for the drawing. SUPPLY SPECIFICATIONS / SPECIFICHE DI FORNITURA. Remove all punching burrs after machining or press-forming process. draft angle 2°. fillets not quoted R=2, internal bend radius as thickness. chamfers not quoted: 0.5x45°. For other specifications please contact the technical department.

□	0.4	—	0.2/100
○	0.4	//	0.2/100
◎	0.25	⊥	0.2/100

Angles ± 1°
Angoli ± 1°

General tolerance - Tolleranza generale: UNI EN 227 68/1 - C					
Length and diam. Lung. e diametri	0.00	6.00	30.0	120	>
Tolerance Tolleranza	± 0.2	± 0.5	± 0.8	± 1.2	± 2.0
	± 4.0	± 5.0	± 3.0	± 4.0	± 5.0

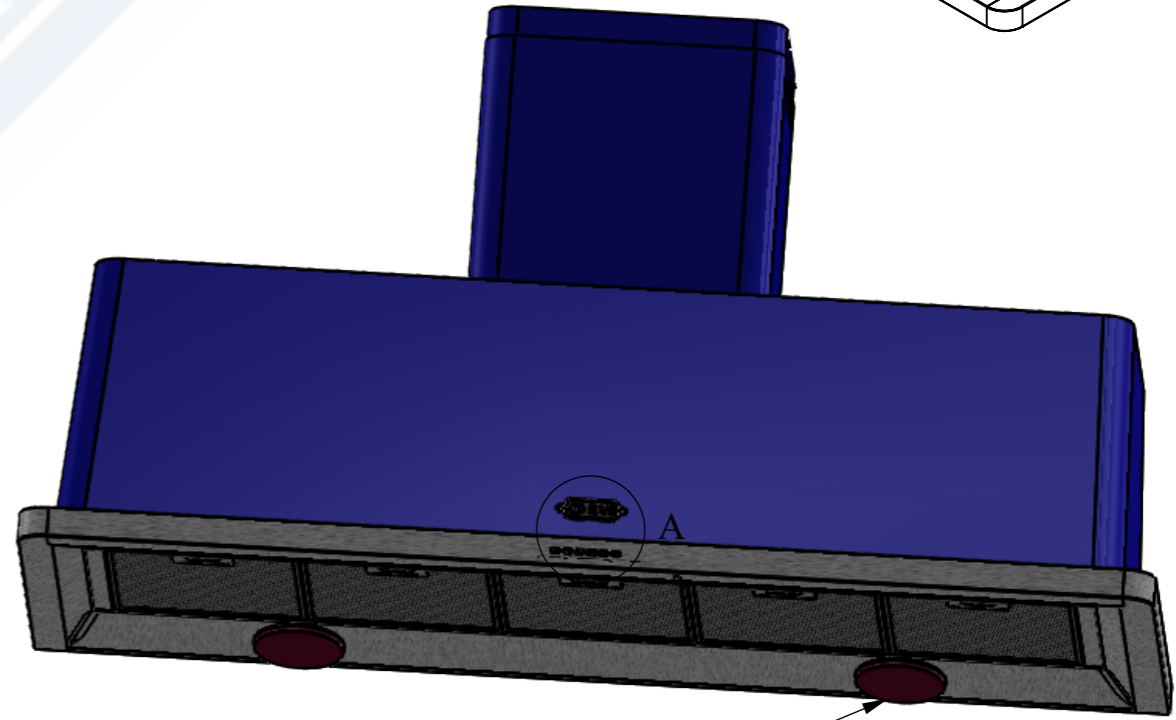
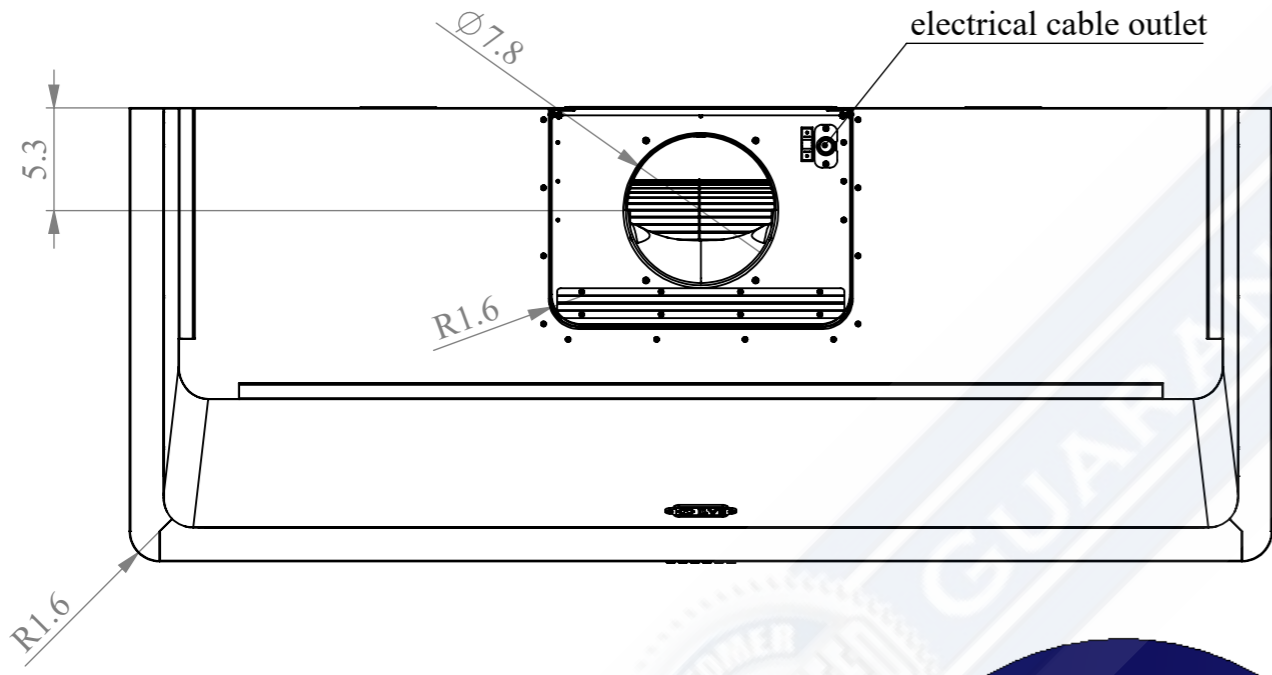
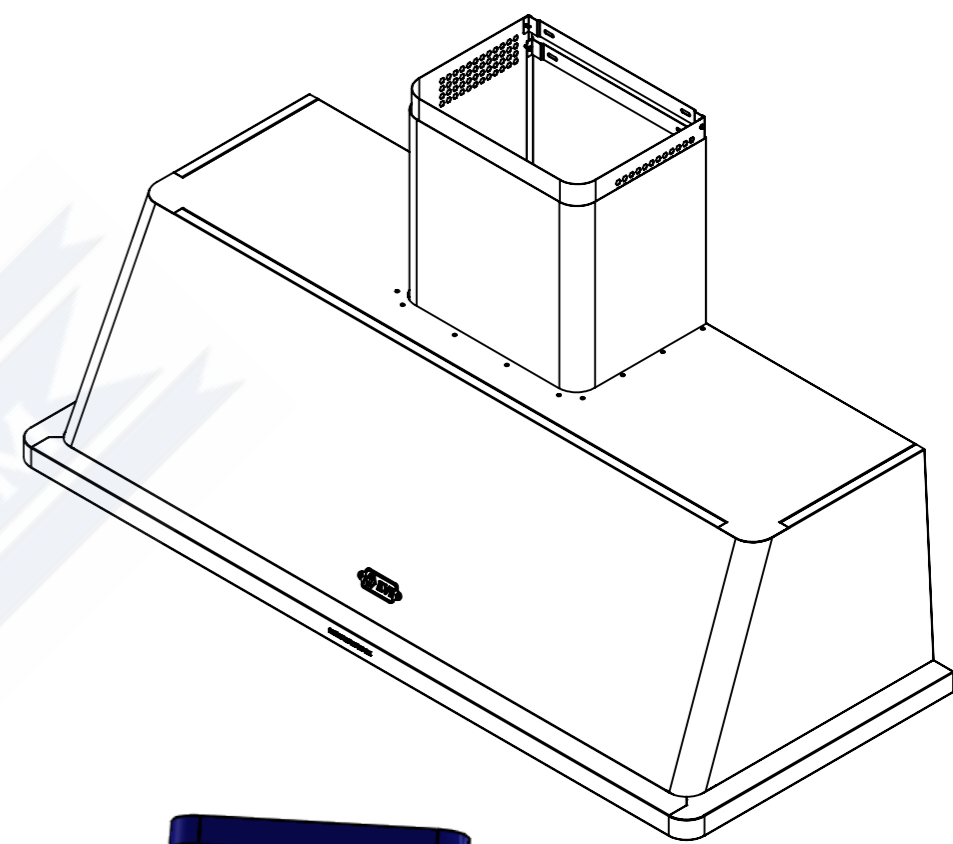
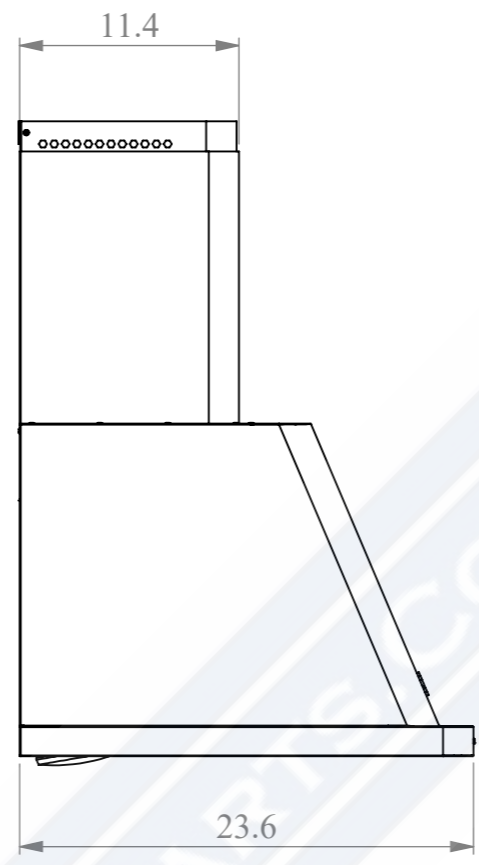
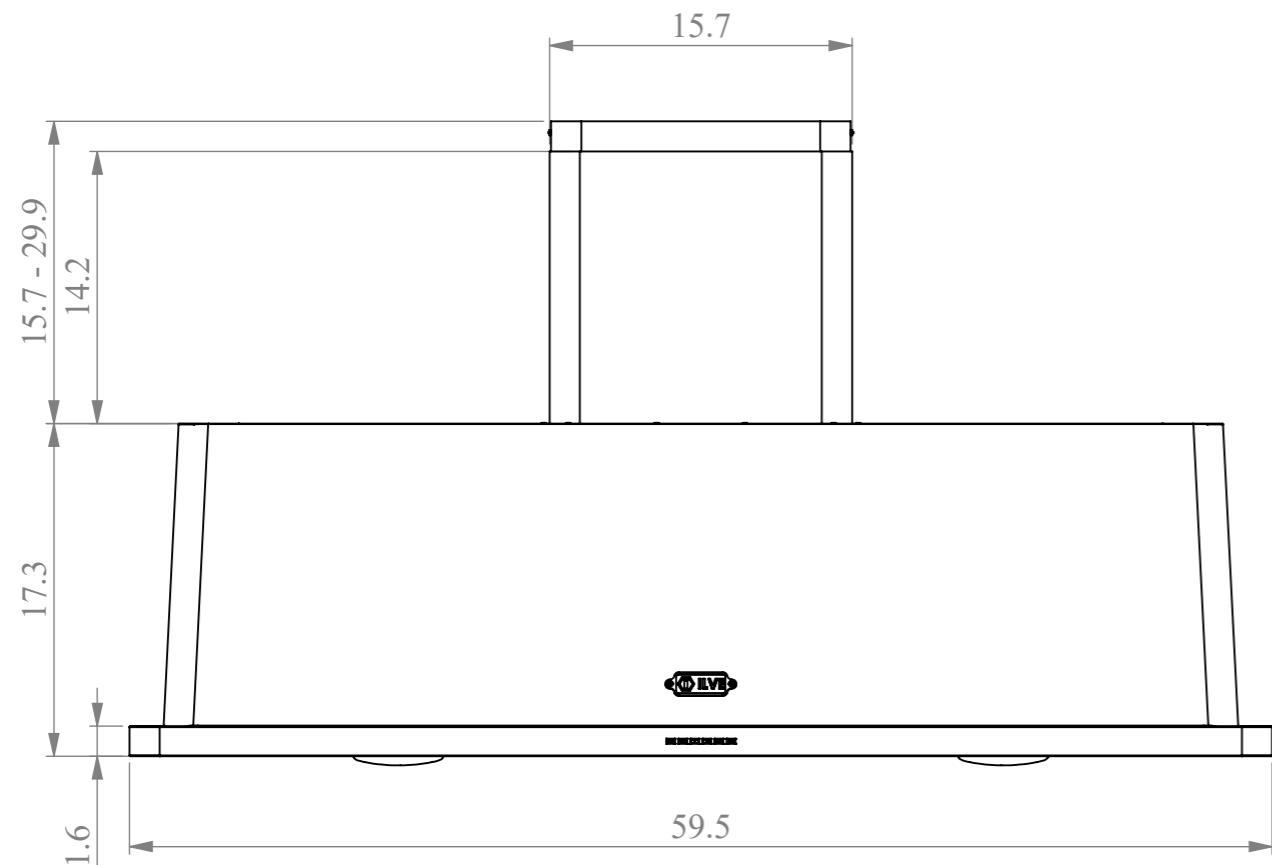

DETAGLIO A
SCALA 1 : 2

COD	COLOR
MG	MAT GRAPHITE
EG	EMERALD GREEN
BU	BURGUNDY
BK	BLACK
WH	WHITE
AW	ANTIQUE WHITE
MB	MIDNIGHT BLUE
SS	STAINLESS STEEL

ILVE	PROGETTO/Project	CLIENTE	SIMMETRICO/Simmetrical code	TIPO/Type	GRUPPO/Group
	USA				
	RIFERIMENTO / Reference	CODICE CLIENTE	MATERIALE/Material	FIRMA/Sign	PESO/Weight (kg)
			GREZZO/Stock size	MO	Orientamento
			mm		
			FINITURA/Finish	SCALA/Scale	DATA/Date
				1:10	26/06/20
			DISEGNO NR./Drawing no.	REV/Rev	
			HOOD MAJESTIC 150 UL 1400	UAM150	00

Il presente disegno è proprietà della ILVE SPA Non può essere copiato o mostrato a terzi senza preventiva autorizzazione scritta. La Società tutelerà a termini di legge. This drawing is property of ILVE SPA an may not be reproduced nor disclosed to third parties without the written consent of ILVE SPA Any abuse will be prosecuted.

PIEGHE IN GIU'
PIEGHE IN SU'

This drawing contains confidential information and is the property of ILVE SPA. Without whose permission it may not be copied, shown or handed to a third party or otherwise used, and it is to be returned promptly upon request to the ILVE SPA, which is responsible for the drawing. SUPPLY SPECIFICATIONS / SPECIFICHE DI FORNITURA
Remove all punching burrs after machining or press-forming process. draft angle 2°
fillets not quoted R=2, internal bend radius as thickness, chamfers not quoted: 0.5x45°.
For other specifications please contact the technical department.

0.4	0.2/100
0.4	0.2/100
0.25	0.2/100

Angles ± 1°
Angoli ± 1°

General tolerance - Tolleranza generale: UNI EN 227 68/1 - C	
Length and diam. Lungn. e diametri	> 315 1000 2000 4000
Tolerance Tolleranza	± 0.2 ± 0.5 ± 0.8 ± 1.2 ± 2.0 ± 3.0 ± 4.0 ± 5.0

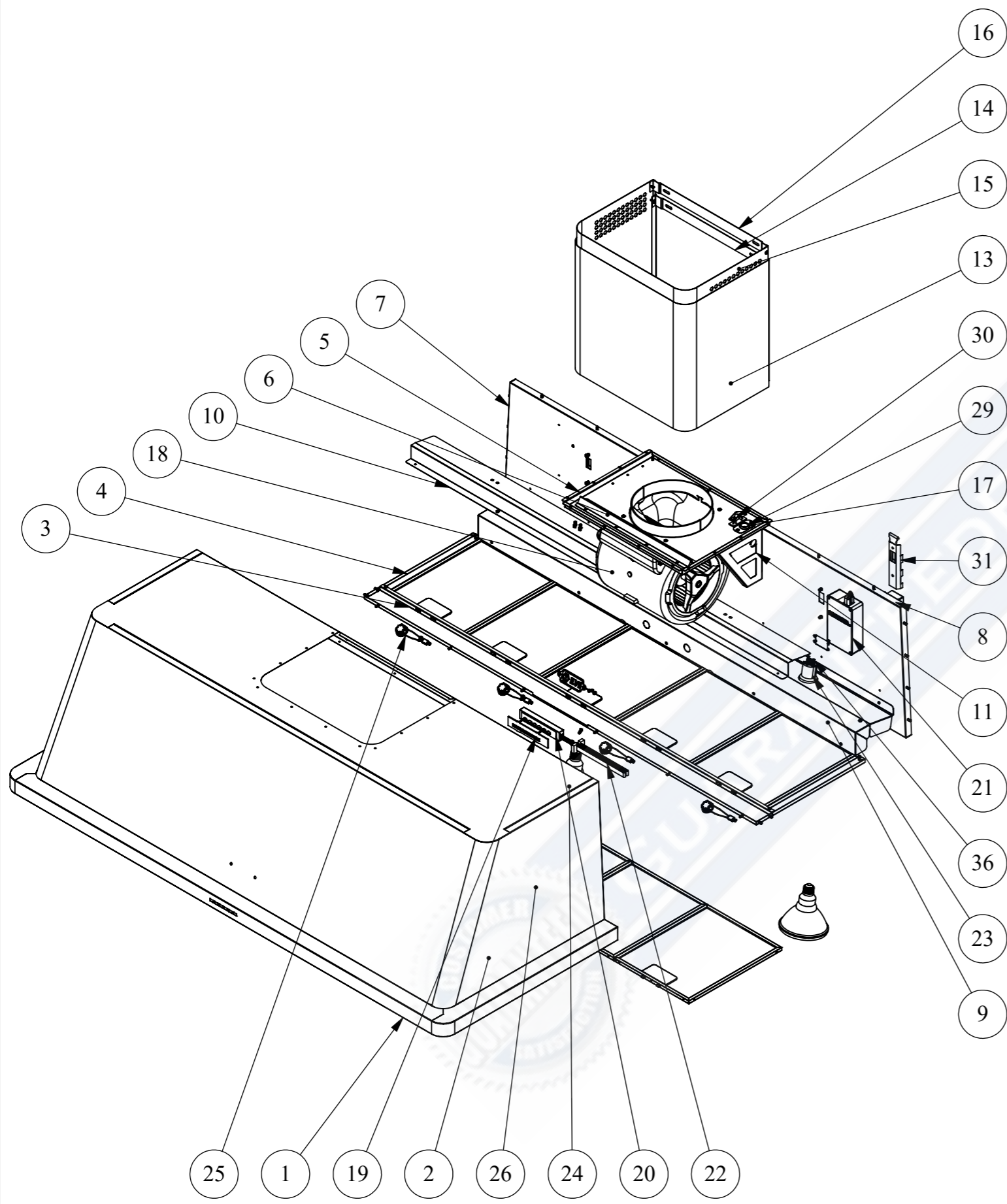

40	2	LV00821500	DADO ESAG.M4 AUTOBLOCCANTE
39	2	LV00824700	VITE TSP+ M4X16 INOX ISO 7046/2
38	4	LV00964900	00 VITE aut. TC+ 4.2x13 NIC
37	4	LV00073700	VITE TC+ M4x10 ZB
36	4	LV00964600	00 VITE TC ES INC M4X20 INOX
35	9	LV00018700	01 INSERTO M4 CH6 TESTA RIDOTTA
34	55	LV00019900	RIVETTO 3.2x10.4 ALLUMINIO
33	63	LV00072000	VITE aut. TC+ 3.9x13 ZB SP
32	2	LV00022901	PIASTRA AGGANCIO
31	2	LV00027100	ATTACCAGLIA 624.400.033
30	1	LV00694200	BLOCCACAVI IN PLASTICA PA238RO
29	1	LV00103000	GOMMINO PASSACAVI Ø 22
28	1	LV00659200	PASSACAPO PVC KP 9-12-16-2
27	1	A30200064	00 Marchietto ilve
26	9	LV00285100	FILTRO ALLUMINIO P320 x L258
25	4	A40300013	FAR.LED CROMO 1 W 350mA 3000°K (UL/CSA)
24	2	LV00964400	00 LAMPADA INFRAR. Par38 IR 175W E27 110V
23	2	LV00964300	00 PORTALAMPADA E27 PORCELLANA BIANCA
22	1	LV00663500	00 PROLUNGA PULSANTIERE
21	1	LV00965100	00 MAIN I.E. 110V + 2 LAMP. INFRAROSSO+ Alimentatore + CABLAGGIO UL
20	1	LV00964700	00 COMANDI RETT. 6T UL
19	1	LV00785000	PLASTICA FISS. COMANDI RETT.
18	1	D2E160GL2121LW	00 D2E160GL2121_LW 1500m3/h
17	1	LV000528_00	CHIUSURA CAVI
16	1	MJ100C022	00 STAFFA PROLUNGA
15	1	MJ100C021	00 PROLUNGA CAMINO
14	1	MJ100C020	00 STAFFA CAMINO
13	1	MJ100C019	00 CAMINO ESTERNO
12	1	MJ100C018	00 RINFORZO SX MOTORE
11	1	MJ100C017	00 RINFORZO DX MOTORE
10	1	MJ150C016	00 SUPPORTO LAMPADE
9	1	MJ150C015	00 PROTEZIONE LAMPADE 1511
8	2	MJ100C014	00 STAFFA SICUREZZA
7	1	MJ150C013	00 SCHIENALE
6	1	MJ100C012	00 RINFORZO BASE MOTORE
5	1	MJ100C011	00 BASE MOTORE EBM1400
4	2	MJ150C010	00 DISTANZIALE FILTRI LATERALE 1511
3	1	MJ150C009	00 DISTANZIALE FRONTALE FILTRI 1511
2	1	MJ150A002	00 ASSIEME MANTELLO 1511
1	1	MJ150A001	00 ASSIEME CRUSCOTTO 1511

Pos.	Qtà	CODICE/Code	Rev	DESCRIZIONE/Description		
		PROGETTO/Project	CLIENTE	SIMMETRICO/Simmetrical code	TIPO/Type	GRUPPO/Group
		RIFERIMENTO / Reference	CODICE CLIENTE	MATERIALE/Material		PESO/Weight (kg)
				GREZZO/Stock size	FIRMA/Sign	Orientamento
				mm	MO	
				FINITURA/Finish	SCALA/Scale	DATA/Date
					1:10	26/06/20
DENOMINAZIONE/Name				DISEGNO NR./Drawing no.		REV/Rev
HOOD MAJESTIC 150 UL 1400				UAM150		00
<small>Il presente disegno è proprietà della ILVE SPA Non può essere copiato o mostrato a terzi senza preventiva autorizzazione scritta. La Società tutelera a termini di legge. This drawing is property of ILVE SPA an may not be reproduced nor disclosed to third parties without the written consent of ILVE SPA Any abuse will be prosecuted.</small>						