

PIEGHE IN GIU'
PIEGHE IN SU'

This drawing contains confidential information and is the property of ILVE SPA, without whose permission it may not be copied, shown or handed to a third party or otherwise used, and it is to be returned promptly upon request to the ILVE SPA, which is responsible for the drawing. SUPPLY SPECIFICATIONS / SPECIFICHE DI FORNITURA. Remove all punching burrs after machining or press-forming process. draft angle 2°. fillets not quoted R=2, internal bend radius as thickness, chamfers not quoted: 0.5x45°. For other specifications please contact the technical department.

0.4	0.2/100
0.4	0.2/100
0.25	0.2/100

Angles ± 1°
Angoli ± 1°

General tolerance - Tolleranza generale: UNI EN 227 68/1 - C	
Length and diam. Lung. e diametri	> 4000 2000 1000 315 120 30.0
Tolerance Tolleranza	± 5.0 ± 4.0 ± 3.0 ± 2.0 ± 1.2 ± 0.8 ± 0.5 ± 0.2

COD	COLOR
MG	MAT GRAPHITE
EG	EMERALD GREEN
BU	BURGUNDY
BK	BLACK
WH	WHITE
AW	ANTIQUE WHITE
MB	MIDNIGHT BLUE
SS	STAINLESS STEEL

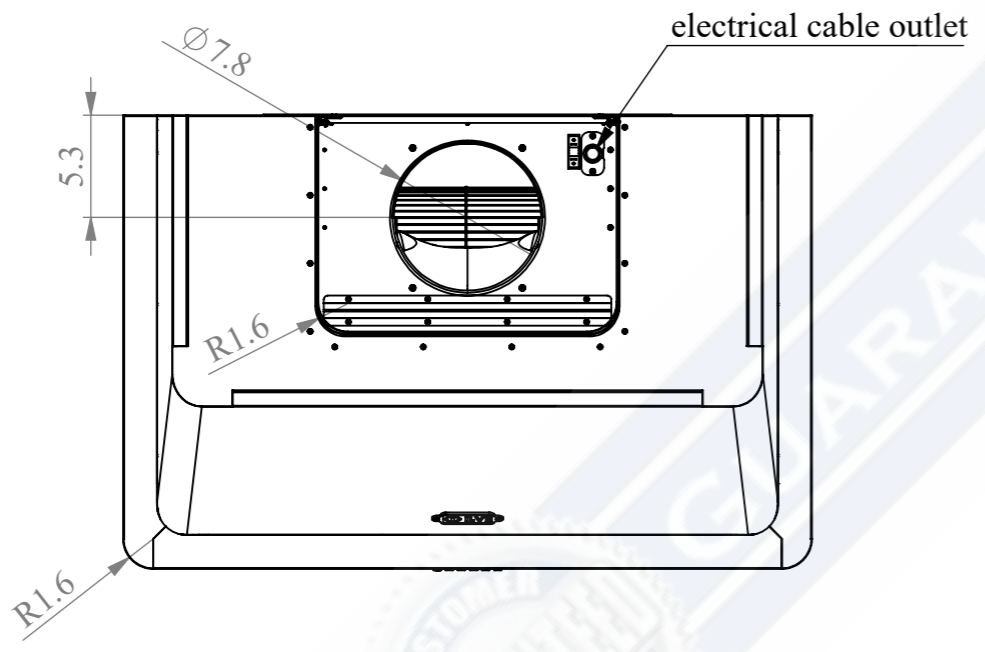
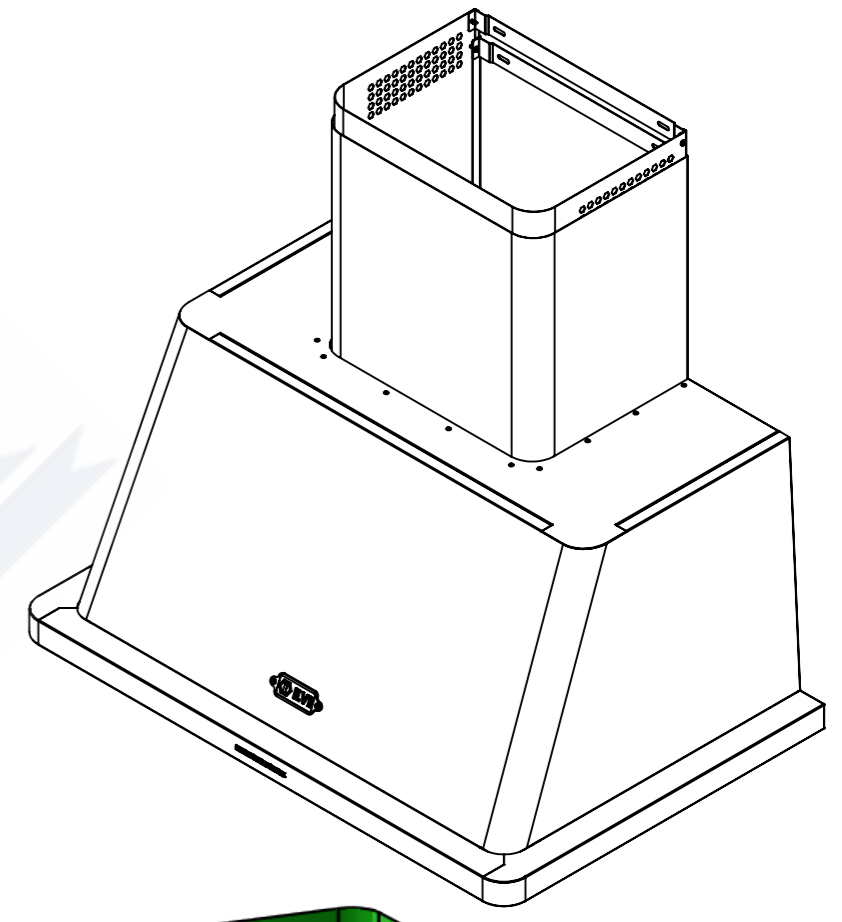
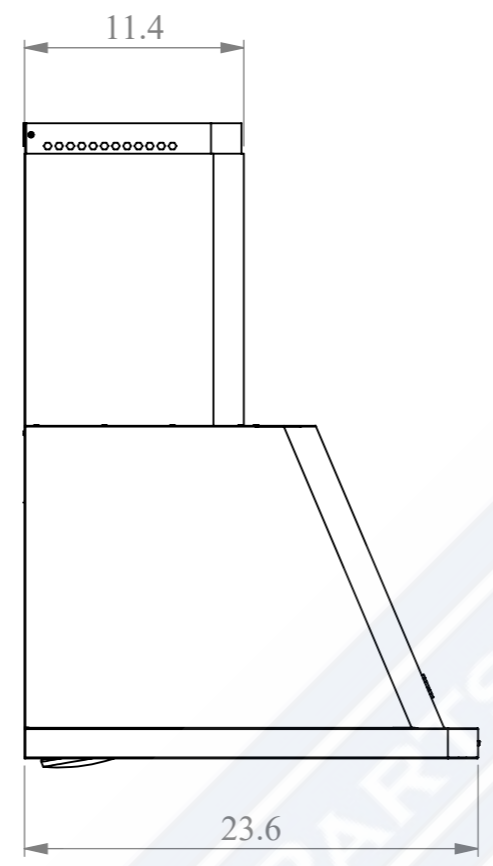
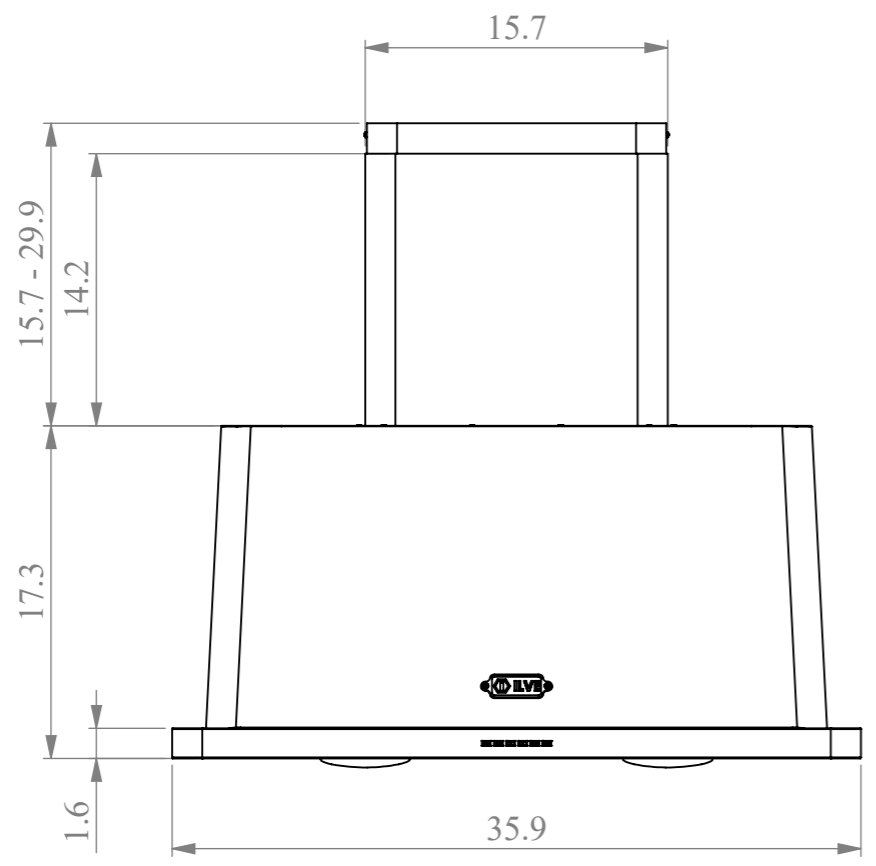

DETTAGLIO A
SCALA 1 : 2

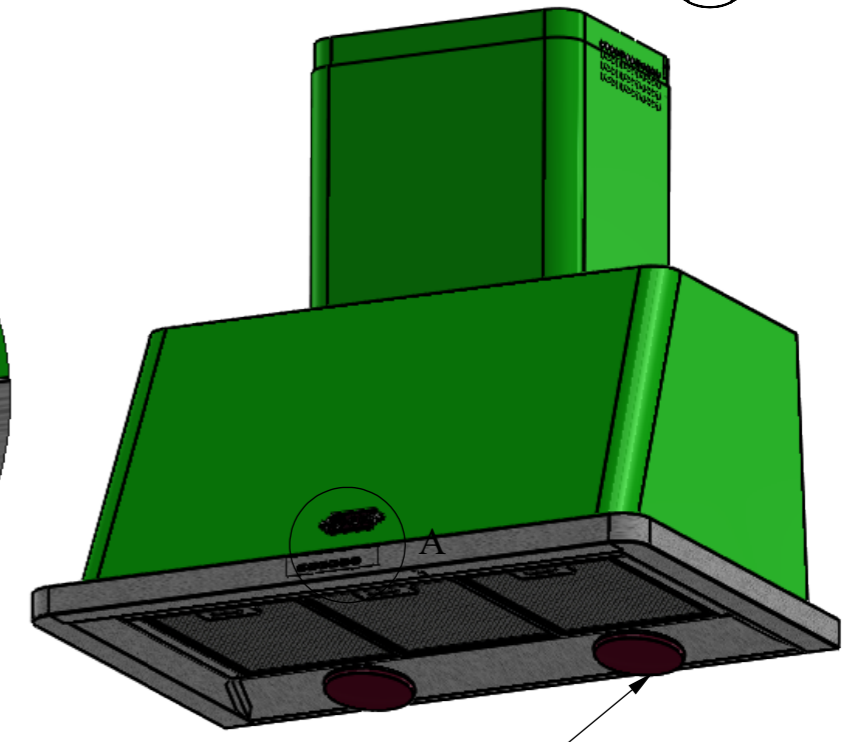

infrared lamps 2x175 watts

ILVE	PROGETTO/Project	CLIENTE	SIMMETRICO/Simmetrical code	TIPO/Type	GRUPPO/Group
	USA				
	RIFERIMENTO / Reference	CODICE CLIENTE	MATERIALE/Material	FIRMA/Sign	PESO/Weight (kg)
			GREZZO/Stock size	MO	Orientamento
			<i>mm</i>	SCALA/Scale	DATA/Date
			FINITURA/Finish	1:10	29/06/20
DENOMINAZIONE/Name			DISEGNO NR./Drawing no.	REV/Rev	
HOOD MAJESTIC 90 UL 1400			UAM90	00	
Il presente disegno è proprietà della ILVE SPA Non può essere copiato o mostrato a terzi senza preventiva autorizzazione scritta. La Società tutelerà a termini di legge. This drawing is property of ILVE SPA an may not be reproduced nor disclosed to third parties without the written consent of ILVE SPA Any abuse will be prosecuted.					

PIEGHE IN GIU'
PIEGHE IN SU'

This drawing contains confidential information and is the property of ILVE SPA. Without whose permission it may not be copied, shown or handed to a third party or otherwise used, and it is to be returned promptly upon request to the ILVE SPA, which is responsible for the drawing. SUPPLY SPECIFICATIONS / SPECIFICHE DI FORNITURA. Remove all punching burrs after machining or press-forming process. draft angle 2°. fillets not quoted R=2, internal bend radius as thickness. chamfers not quoted: 0.5x45°. For other specifications please contact the technical department.

0.4	0.2/100
0.4	0.2/100
0.25	0.2/100

Angles ± 1°
Angoli ± 1°

General tolerance - Tolleranza generale: UNI EN 227 68/1 - C	
Length and diam. Lungn. e diametri	> 315 1000 2000 4000
Tolerance Tolleranza	± 0.2 ± 0.5 ± 0.8 ± 1.2 ± 2.0 ± 3.0 ± 4.0 ± 5.0

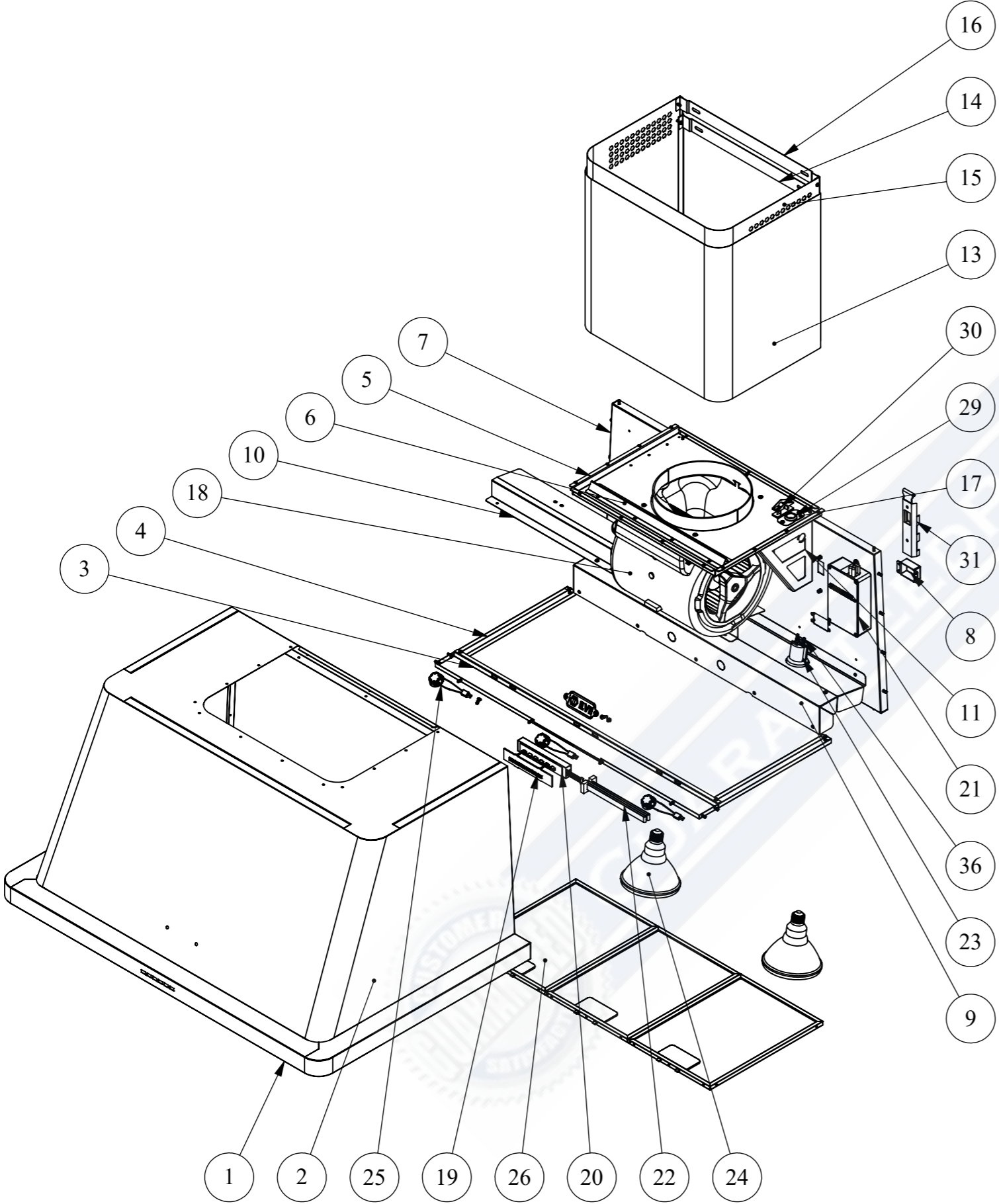

40	2	LV00821500	DADO ESAG.M4 AUTOBLOCCANTE
39	2	LV00824700	VITE TSP+ M4X16 INOX ISO 7046/2
38	4	LV00964900	00 VITE aut. TC+ 4.2x13 NIC
37	4	LV00073700	VITE TC+ M4x10 ZB
36	4	LV00964600	00 VITE TC ES INC M4X20 INOX
35	9	LV00018700	01 INSERTO M4 CH6 TESTA RIDOTTA
34	53	LV00019900	RIVETTO 3.2x10.4 ALLUMINIO
33	55	LV00072000	VITE aut. TC+ 3.9x13 ZB SP
32	2	LV00022901	PIASTRA AGGANCIO
31	2	LV00027100	ATTACCAGLIA 624.400.033
30	1	LV00694200	BLOCCACAVI IN PLASTICA PA238RO
29	1	LV00103000	GOMMINO PASSACAVI Ø 22
28	1	LV00659200	PASSACAVO PVC KP 9-12-16-2
27	1	LVA30200064	00 Marchietto ilve
26	3	LV00964800	00 FILTRO ALLUMINIO P320 x L233 SP9 6+2
25	3	LVA40300013	FAR.LED CROMO 1 W 350mA 3000°K (UL/CSA)
24	2	LV00964400	00 LAMPADA INFRAR. Par38 IR 175W E27 110V
23	2	LV00964300	00 PORTALAMPADA E27 PORCELLANA BIANCA
22	1	LV00663500	00 PROLUNGA PULSANTIERE
21	1	LV00965100	00 MAIN I.E. 110V + 2 LAMP. INFRAROSSO+ Alimentatore + CABLAGGIO UL
20	1	LV00964700	00 COMANDI RETT. 6T UL
19	1	LV00785000	PLASTICA FISS. COMANDI RETT.
18	1	LVD2E160GL2121LW	00 D2E160GL2121_LW 1500m3/h
17	1	LV00052800	CHIUSURA CAVI
16	1	LVMJ100C022	00 STAFFA PROLUNGA
15	1	LVMJ100C021	00 PROLUNGA CAMINO
14	1	LVMJ100C020	00 STAFFA CAMINO
13	1	LVMJ100C019	00 CAMINO ESTERNO
12	1	LVMJ100C018	00 RINFORZO SX MOTORE
11	1	LVMJ100C017	00 RINFORZO DX MOTORE
10	1	LVMJ090C016	00 SUPPORTO LAMPAD E 911
9	1	LVMJ090C015	00 PROTEZIONE LAMPAD E 911
8	2	LVMJ100C014	00 STAFFA SICUREZZA
7	1	LVMJ090C013	00 SCHIENALE 911
6	1	LVMJ100C012	00 RINFORZO BASE MOTORE
5	1	LVMJ100C011	00 BASE MOTORE EBM1400
4	2	LVMJ090C010	00 DISTANZIALE FILTRI LATERALE 911
3	1	LVMJ090C009	00 DISTANZIALE FRONTALE FILTRI 911
2	1	LVMJ090A002	00 ASSIEME MANTELLO 911
1	1	LVMJ090A001	00 ASSIEME CRUSCOTTO 911

Pos.	Qtà	CODICE/Code	Rev	DESCRIZIONE/Description
		PROGETTO/Project	CLIENTE	SIMMETRICO/Simmetrical code
		RIFERIMENTO / Reference	CODICE CLIENTE	TIPO/Type
				GRUPPO/Group
				MATERIALE/Material
				GREZZO/Stock size
				mm
				FINITURA/Finish
				SCALA/Scale
				DATA/Date
				1:10
				29/06/20
				REVISIONI/Revisions
				REV/Rev
				00
				DISEGNO NR./Drawing no.
				UAM90

Il presente disegno è proprietà della ILVE SPA. Non può essere copiato o mostrato a terzi senza preventiva autorizzazione scritta. La Società tutelera a termini di legge. This drawing is property of ILVE SPA. It can not be reproduced nor disclosed to third parties without the written consent of ILVE SPA. Any abuse will be prosecuted.