

24/25

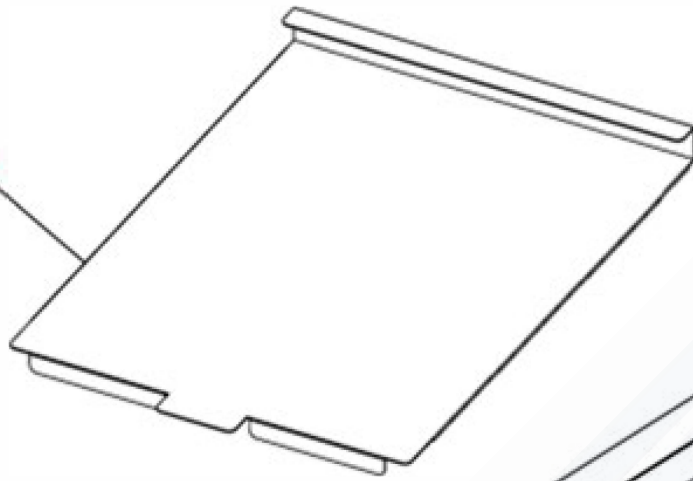

26/27



23



30



31



LABEL NO.	MVP PART NO.	MVP PART NO. DESCRIPTION
1	1190270	FRONT PANEL FOR FRYER
2	1190168	DOOR ASSEMBLY, 3+4 TUBE FRYER (DOOR/HANDLE/HINGE/ROD)
3	1190172	DOOR ASSEMBLY, 5-TUBE FRYER (DOOR/HANDLE/HINGE/ROD)
4	1190001	DOOR MAGNET
5	1190003	SCREEN -TUBE, FRYER 3 TUBE
6	1190352	SCREEN -TUBE, FRYER 4 TUBE
7	1190026	SCREEN - TUBE, FRYER 5 TUBE
8	1190007	CAST IRON BURNER, FRYER
9	1190008	VALVE, COMBI, MILLI-VOLT, NG
10	1190009	VALVE, COMBI, MILLI-VOLT, LP
11	1190010	HI LIMIT
12	1190011	THERMOSTAT
13	1190012	KNOB, THERMOSTAT
14	1190013	THERMOPILE
15	1190015	BURNER, PILOT, LP
16	1190351	BURNER, PILOT, NG
17	1190016	TUBE, FLEXIBLE, 1/4", 23IN, PILOT
18	1190017	VALVE, BALL, DRAIN, 1-1/4"
19	1190018	DRAIN, EXTENSION
20	1190283	ORIFICE # 39 (NAT), USE PART# 266003 KIT OF 5
21	1190284	ORIFICE # 52 (LP), USE PART# 266002 KIT OF 5
22	1190006	KIT ORIFICE EXTENSION KIT OF 5
23	1190032	TANK CLEANING TOOLS (BRUSH, SCOOP, ROD)
24	1190144	TANK COVERS, 3&4 TUBE FRYERS (10/CARTON)
25	1190145	TANK COVERS, 5-TUBE FRYERS (10/CARTON)
26	1190146	CONNECTING STRIPS, 3&4 TUBE FRYERS (10/CARTON)
27	1190147	CONNECTING STRIPS, 5 TUBE FRYERS (10/CARTON)
28	1190031	CASTER SET; NON-ADJ. & SWIV.
29	1190021	CASTER SET; ADJ. & SWIV.
30	1190055	COVERSION KIT, FRYER NG TO LP
31	1190353	COVERSION KIT, FRYER LP TO NG
32		Left side panel 3+4 TUBE FRYER
33		Right side panel 3+4 TUBE FRYER
34		Left side panel 3+4 TUBE FRYER
35		Right side panel 3+4 TUBE FRYER