

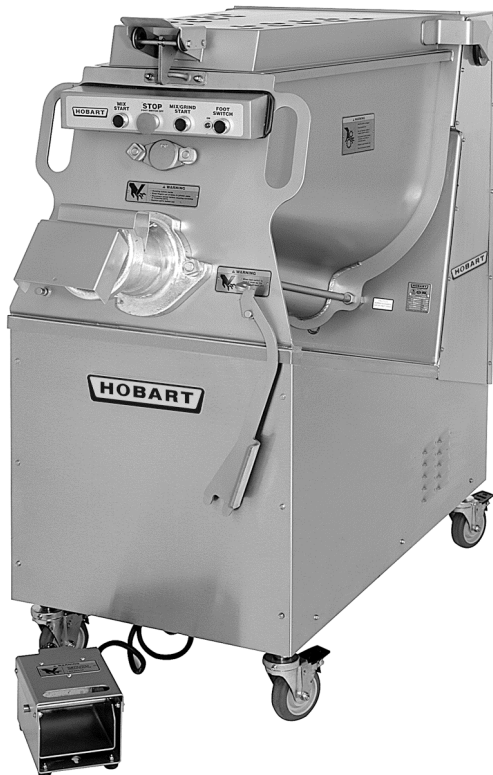

CATALOG OF REPLACEMENT PARTS



A.) MG1532 & MG2032 MIXER-GRINDERS

STANDARD HOPPER (W/TOP FEED)

ML-134099	MG1532
ML-134103	MG1532 (5HP)
ML-134104	MG2032

OPTIONAL HOPPER (W/SIDE FEED)

ML-134100	MG1532
ML-134105	MG2032

PRIOR ML'S COVERED IN THIS
MANUAL

STANDARD HOPPER (W/TOP FEED)

ML-104878	MG1532
ML-104883	MG1532 (5HP)
ML-104884	MG2032

OPTIONAL HOPPER (W/SIDE FEED)

ML-104879	MG1532
ML-104885	MG2032

MIXER-GRINDER (W/SPECIAL POWER CORD)

ML-104882	MG1532
-----------	--------

Table of Contents

5	CONTROL BOX
7	CONTROL BOX COMPONENTS (BEFORE S/N 27112072) (TDR TYPE)
9	CONTROL BOX COMPONENTS (S/N 27112072 THRU S/N 311567619)
11	CONTROL BOX COMPONENTS (STARTING S/N 311567619)
13	OPERATOR CONTROL PANEL
15	TOP COVER UNIT
17	HINGE UNIT
19	CONVEYOR AND MIXING ARM UNIT
21	FRAME AND HOPPER UNIT
23	ACCESSORIES
25	MIX MOTOR UNIT
27	GRIND MOTOR UNIT
29	FOOT SWITCH UNIT (PNEUMATIC)
31	TRANSMISSION UNIT
33	#32 GRINDER UNIT

- | | | |
|----|-----------------|-------------------|
| 29 | 00-478551-00002 | Cord & Plug Assy. |
| 30 | 00-117612-00016 | Cord & Plug Assy. |
| 31 | 00-478551-00001 | Cord & Plug Assy. |
| 32 | 00-294899-00001 | Cord & Plug Assy. |

PARTS NOT ILLUSTRATED

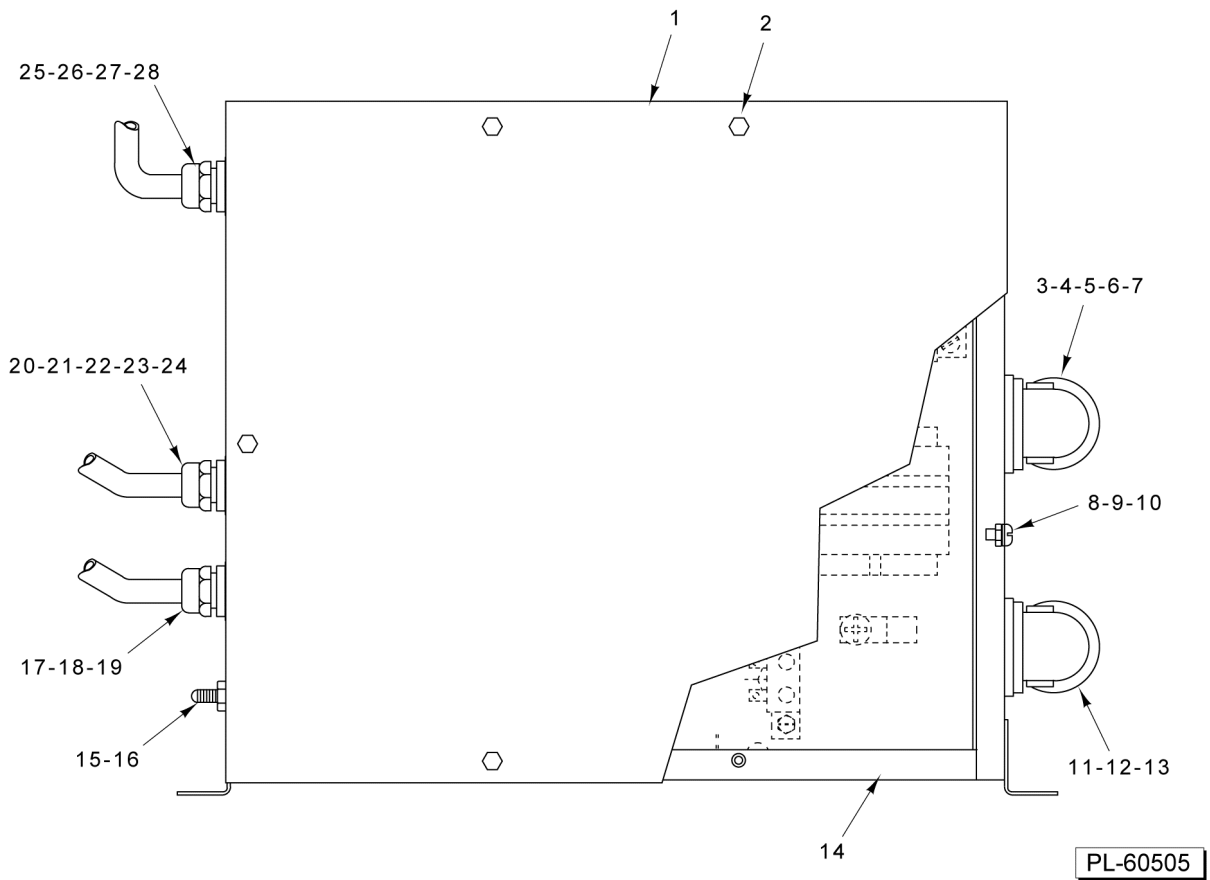

CONTROL BOX

CONTROL BOX

ILLUS.	PART NO.	NAME OF PART	AMT.
PL-60505			
1	00-477954	Cover Assy. - Control Box.....	1
2	SD-036-39	Self-Tapping Screw 10-24 x 3/8 Slotted. Truss Hd., Type TT (SST).....	6
3	00-294853-00019	Cable - Motor Control Grind (MG1532).....	1
4	00-294853-00027	Cable - Motor Control Grind (MG2032).....	1
5	FE-023-41	Strain Relief.....	1
6	FE-006-50	Lock Nut.....	1
7	FE-008-12	Gasket.....	1
8	SC-008-17	Mach. Screw 10-32 x 3/8 Slotted Rd. Hd.....	1
9	WL-007-12	Lockwasher #10 External Shakeproof.....	1
10	NS-009-30	Nut 10-32 Hex.....	1
11	FE-023-42	Strain Relief.....	1
12	FE-006-50	Lock Nut.....	1
13	FE-008-12	Gasket.....	1
14	00-478742-00001	Box - Lower Control.....	1
15	00-087711-213-1	Switch - Air Actuated.....	1
16	00-294855-00001	Cap - Skid Retaining.....	1
17	00-294853-00037	Cable - Control Switch.....	1
18	FE-025-93	Strain Relief.....	1
19	FE-024-88	Lock Nut 1/2 Electrical.....	1
20	00-294853-00042	Cable - Mix Motor Control (MG2032).....	1
21	00-294853-00041	Cable - Mix Motor Control (MG1532).....	1
22	00-294853-00036	Cable - Mix Motor Control (MG1532) (1 Ph.).....	1
23	FE-025-93	Strain Relief.....	1
24	FE-024-88	Lock Nut 1/2 Electrical.....	1
25	00-294853-00038	Cable - Interlock Switch (MG1532).....	1
26	00-294853-00040	Cable - Interlock Switch (MG2032).....	1
27	FE-022-84	Connector - Strain Relief.....	1
28	FE-024-88	Lock Nut 1/2 Electrical.....	1
29	00-478551-00002	Cord & Plug Assy. 240 V. (3 Ph.).....	1
30	00-117612-00016	Cord & Plug Assy. 480 V. (3 Ph.).....	1
31	00-478551-00001	Cord & Plug Assy. 208 V. (3 Ph.).....	1
32	00-294899-00001	Cord & Plug Assy. (1 Ph.).....	1

THESE COMPONENTS USED ON:

ML-104787 ML-104884 ML-104879 ML-104885
 ML-104882 ML-104883

AND THESE MACHINES PRIOR TO:

S/N271112484 ML-134099
 S/N271112986 ML-134100
 S/N271112833 ML-134103
 S/N271112072 ML-134104

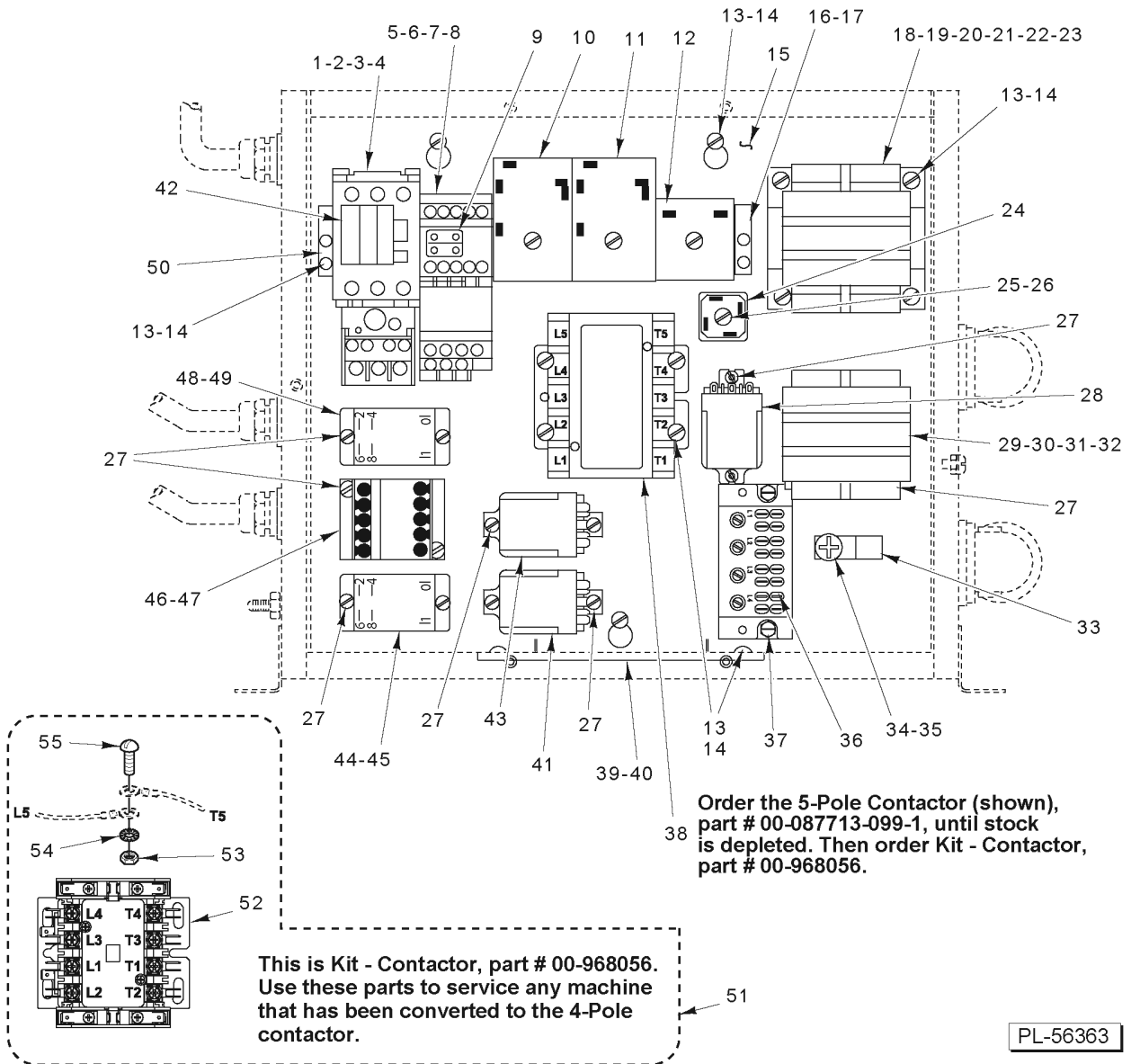

PL-56363

**CONTROL BOX COMPONENTS
 (BEFORE S/N 271112072)
 (TDR TYPE)**

**CONTROL BOX COMPONENTS
(BEFORE S/N 271112072)
(TDR TYPE)**

ILLUS.	PART NO.	NAME OF PART	AMT.
PL-56363			
1	00-087713-094-2	Contactora (50 Amp., 3 Pole) (208 V.) (1 CON).....	1
2	00-087713-094-3	Contactora (240/480 V.) (1 CON).....	1
3	00-088196-024-1	Relay - Overload (208/240) (1 OL).....	1
4	00-088196-024-2	Relay - Overload (480) (1 OL).....	1
5	00-087713-089-3	Contactora (208 V.) (2 CON).....	1
6	00-087713-089-2	Contactora (220-480 V.) (2 CON).....	1
7	00-088196-017-1	Relay - Overload (208/240 V.) (2 OL).....	1
8	00-088196-017-2	Relay - Overload (480 V.) (2 OL).....	1
9	00-087711-00266	Switch - Auxillary.....	1
10	00-087714-048-1	Relay - Time Delay (Brake TDR).....	1
11	00-087714-048-2	Relay - Time Delay (Pause TDR).....	1
12	00-087714-049-1	Timer - Solid State (On TDR).....	1
13	SC-008-11	Mach. Screw 10-24 x 3/4 Slotted Rd. Hd.....	AR
14	WL-007-12	Lockwasher #10 External Shakeproof.....	AR
15	00-479189-00001	Plate - Control Mounting (Weld).....	1
16	00-478219	Bracket - Din Mounting.....	3
17	00-478218	Rail - Stop.....	2
18	00-938712	I Assy, Tranfomer, Low Voltage (208-240V).....	1
19	00-916905-007-2	Transformer (480V).....	1
20	FE-026-15	Fuse (3 Amp.) (208/240 V.).....	2
21	FE-025-50	Fuse (20 Amp.) (208/240 V.).....	1
22	FE-025-57	Fuse (1 Amp.) (380/415/480 V.).....	2
23	FE-025-59	Fuse (10 Amp.) (380/415/480 V.).....	1
24	00-873821	Bridge Rectifier.....	1
25	SC-021-25	Mach. Screw 10-24 x 3/4 Slotted Rd. Hd. (SST).....	1
26	WL-007-12	Lockwasher #10 External Shakeproof.....	1
27	SC-009-09	Mach. Screw 5/16-18 x 5/8 Slotted Rd. Hd.....	AR
28	00-087714-020-3	Relay (3.P.D.T.).....	1
29	00-294500-032-1	Transformer 50 Amp. (480 V.).....	1
30	00-478962	Transformer 50 Amp. (380/415 V.).....	1
31	FE-025-20	Fuse (0.2 Amp.) (600 V.).....	2
32	FE-025-58	Fuse (0.3 Amp.) (600 V.).....	1
33	00-118544-00002	Lug - Grounding.....	1
34	SC-114-29	Mach. Screw 1/4-20 x 3/8 Phil. Pan Hd.....	1
35	WL-007-14	Lockwasher 1/4 External.....	1
36	00-294325-00021	Block - Terminal (4 Pole).....	1
37	SD-038-03	Self-Tapping Screw 10-16 x 3/4 Slotted Truss Hd.,Type B (SST).....	2
38	00-087713-099-1	Contactora (3 CON) (Use until stock is depleted).....	1
39	00-478220-00001	Heater (208 V.).....	1
40	00-478220-00002	Heater (240/480 V.).....	1
*41	00-087714-050-1	Relay SPST - NO (208/240 V.) (Current Sense Relay).....	1
42	00-087711-268-1	Switch - Auxiliary.....	3
43	00-087714-020-3	Relay (3.P.D.T.) (3 CR).....	1
44	00-087714-046-2	Relay - 2 Pole (30 Amp.) (208 V.) (1 CR).....	1
45	00-087714-046-3	Relay - 2 Pole (30 Amp.) (240/480 V.) (1 CR).....	1
46	00-087713-089-3	Contactora (208 V.) (2 CR).....	1
47	00-087713-089-2	Contactora (220-480 V.) (2 CR).....	1
48	00-087714-042-2	Relay (2-Pole) (208 V.) (Brake Ready Relay).....	1
49	00-087714-042-3	Relay (2 Pole) (220-240 V.) (Brake Ready Relay).....	1
50	00-477300-00002	Rail - Din.....	1
51	00-968056	Kit - Contactora Replacement (Incls. Items 51 thru 54).....	1
52	00-916903-00002	Contactora (4-Pole).....	1
53	NS-010-16	Nut 10-24 Hex (Brass).....	1
54	WL-010-06	Lockwasher #10 External Shakeproof.....	1
55	SC-027-41	Mach. Screw 10-24 x 3/8 Slotted Rd. Hd. (Brass).....	1

* 87714-50-2 Relay (480V.) Is No Longer Available

THESE COMPONENTS USED ON MACHINES STARTING WITH:

S/N271112484	ML-134099
S/N271112986	ML-134100
S/N271112833	ML-134103
S/N271112072	ML-134104

44	00-875178-00001	Harness - Wiring
45	00-479302-00001	Harness - Wiring

PARTS NOT ILLUSTRATED

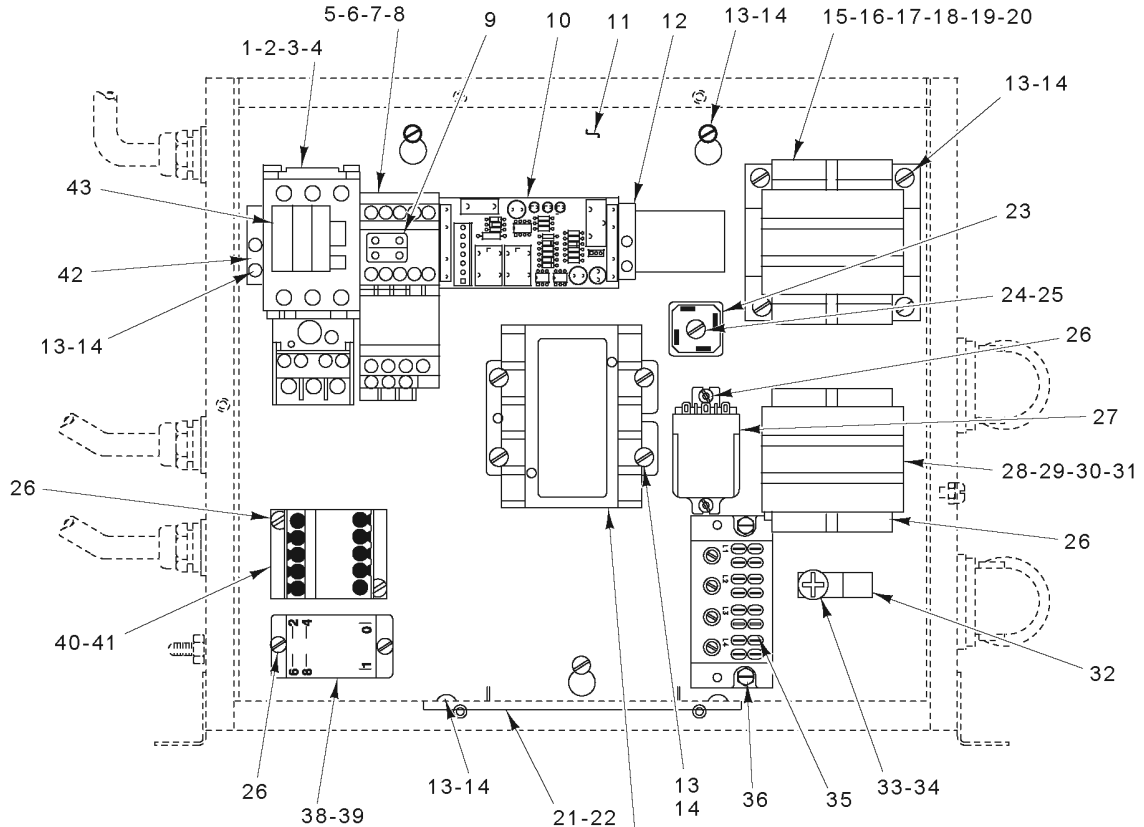

37 Order the 5-Pole Contactor (shown), part # 00-087713-099-1, until stock is depleted. Then order Kit - Contactor, part # 00-968056.

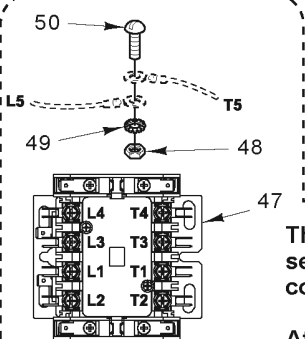

This is Kit - Contactor, part # 00-968056. Use these parts to service any machine that has been converted to the 4-Pole contactor. Usage of this 4-Pole contactor began:

After S/N 311493800 on ML-134104 (MG2032-1)
 After S/N 311494448 on ML-134099 (MG1532-1)
 After S/N 311494832 on ML-134099 (MG1532-7)
 After S/N 311493795 on ML-134101 (MG1532-16)

PL-56187

**CONTROL BOX COMPONENTS
 (S/N 271112072 THRU S/N 311567619)**

**CONTROL BOX COMPONENTS
(S/N 271112072 THRU S/N 311567619)**

ILLUS.	PART NO.	NAME OF PART	AMT.
PL-56187			
1	00-087713-094-2	Contactora (50 Amp., 3 Pole) (208 V.) (1 CON).....	1
2	00-087713-094-3	Contactora (240/480 V.) (1 CON).....	1
3	00-088196-024-1	Relay - Overload (208/240) (1 OL).....	1
4	00-088196-024-2	Relay - Overload (480) (1 OL).....	1
5	00-087713-089-3	Contactora (208 V.) (2 CON).....	1
6	00-087713-089-2	Contactora (220-480 V.) (2 CON).....	1
7	00-088196-017-1	Relay - Overload (208/240 V.) (2 OL).....	1
8	00-088196-017-2	Relay - Overload (480 V.) (2 OL).....	1
9	00-087711-00266	Switch - Auxillary.....	1
10	00-875510	Board - Printed Circuit Assy. (Brake Module).....	1
11	00-479189-00001	Plate - Control Mounting (Weld).....	1
12	00-478218	Rail - Stop.....	2
13	SC-018-11	Mach. Screw 10-24 x 3/8 Slotted Pan Hd.....	AR
14	WL-007-12	Lockwasher #10 External Shakeproof.....	AR
15	00-938712	I Assy, Tranfomer, Low Voltage (208-240V).....	1
16	00-916905-007-2	Transformer (480V).....	1
17	FE-026-15	Fuse (3 Amp.) (208/240 V.).....	2
18	FE-025-50	Fuse (20 Amp.) (208/240 V.).....	1
19	FE-026-96	Fuse (15 Amp.) (480 V.).....	1
20	FE-026-97	Fuse (1.5 Amp.) (480 V.).....	2
21	00-478220-00001	Heater (208 V.).....	1
22	00-478220-00002	Heater (240/480 V.).....	1
23	00-873821	Bridge Rectifier.....	1
24	SC-021-25	Mach. Screw 10-24 x 3/4 Slotted Rd. Hd. (SST).....	1
25	WL-007-12	Lockwasher #10 External Shakeproof.....	1
26	SD-009-09	Self-Tapping Screw 8-32 x 1/2 Slotted Bndg. Hd., Type F.....	AR
27	00-087714-020-3	Relay (3.P.D.T.).....	1
28	00-294500-032-1	Transformer 50 Amp. (480 V.).....	1
29	00-478962	Transformer (380-415 V.).....	1
30	FE-025-20	Fuse (0.2 Amp.) (380/415/480 V.).....	2
31	FE-025-58	Fuse (0.3 Amp.) (380/415/480 V.).....	1
32	00-118544-00002	Lug - Grounding.....	1
33	SC-114-29	Mach. Screw 1/4-20 x 3/8 Phil. Pan Hd.....	1
34	WL-007-14	Lockwasher 1/4 External.....	1
35	00-294325-00021	Block - Terminal (4 Pole).....	1
36	SD-038-03	Self-Tapping Screw 10-16 x 3/4 Slotted Truss Hd., Type B (SST).....	2
37	00-087713-099-1	Contactora (3 CON) (Use until stock is depleted).....	1
38	00-087714-046-2	Relay - 2 Pole (30 Amp.) (208 V.) (1 CR).....	1
39	00-087714-046-3	Relay - 2 Pole (30 Amp.) (240/480 V.) (1 CR).....	1
40	00-087713-089-3	Contactora (208 V.) (2 CR).....	1
41	00-087713-089-2	Contactora (220-480 V.) (2 CR).....	1
42	00-477300-00002	Rail - Din.....	1
43	00-087711-268-1	Switch - Auxiliary.....	3
44	00-875178-00001	Harness - Wiring (Main Wiring Harness).....	1
45	00-479302-00001	Harness - Wiring.....	1
46	00-968056	Kit - Contactora Replacement (Incls. Items 46 thru 49).....	1
47	00-916903-00002	Contactora (4-Pole).....	1
48	NS-010-16	Nut 10-24 Hex (Brass).....	1
49	WL-010-06	Lockwasher #10 External Shakeproof.....	1
50	SC-027-41	Mach. Screw 10-24 x 3/8 Slotted Rd. Hd. (Brass).....	1

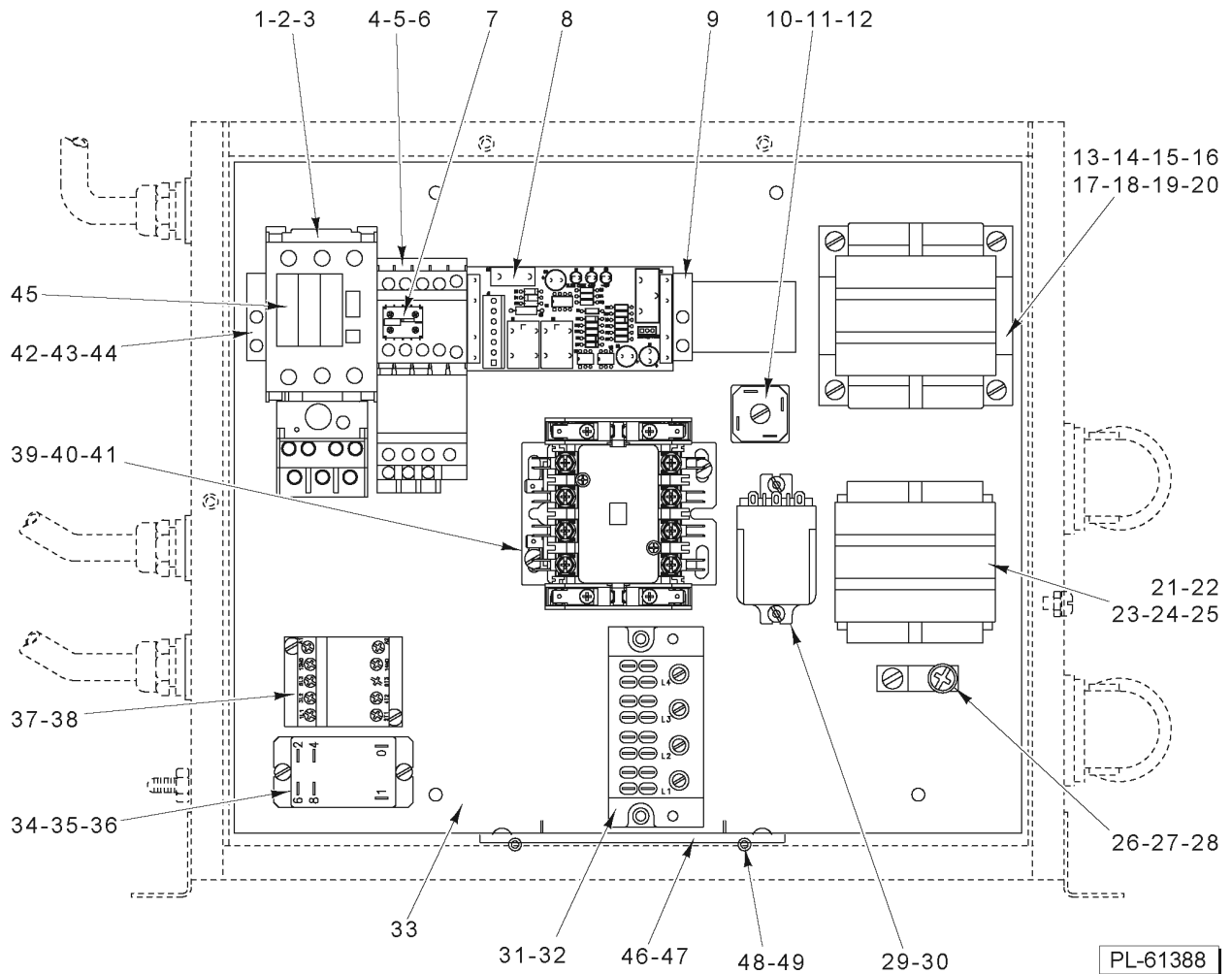

**CONTROL BOX COMPONENTS
(STARTING S/N 311567619)**

CONTROL BOX COMPONENTS (STARTING S/N 311567619)

ILLUS. PL-61388	PART NO.	NAME OF PART	AMT.
1	00-937850	Contactora (1CON).....	1
2	00-937851-00001	Relay - Overload (200-220/208/240 V.) (1OL).....	1
3	00-937851-00002	Relay - Overload (380-415/480 V.) (1OL).....	1
4	00-937849	Contactora (2CON).....	1
5	00-937847-00001	Relay - Overload (200-220/208/240 V.) (2OL).....	1
6	00-937847-00002	Relay - Overload (380-415/480 V.) (2OL).....	1
7	00-937846	Switch - Auxiliary.....	1
8	00-875510	Board - Printed Circuit Assy. (Brake Module).....	1
9	00-478218	Rail - Stop.....	2
10	00-873821	Bridge Rectifier.....	1
11	SC-021-25	Mach. Screw 10-24 x 3/4 Slotted Rd. Hd. (SST).....	1
12	WL-007-12	Lockwasher #10 External Shakeproof.....	1
13	00-938712	I Assy, Tranfomer, Low Voltage (208-240V).....	1
14	00-916905-007-2	Transformer (480V).....	1
15	FE-026-15	Fuse (3 Amp.) (200-220/208/240 V.).....	2
16	FE-026-97	Fuse (1.5 Amp.) (380-415/480 V.).....	2
17	FE-025-50	Fuse (20 Amp.) (200-220/208/240 V.).....	1
18	FE-026-96	Fuse (15 Amp.) (380-415/480 V.).....	1
19	SC-018-11	Mach. Screw 10-24 x 3/8 Slotted Pan Hd.....	4
20	WL-007-12	Lockwasher #10 External Shakeproof.....	4
21	00-294500-032-1	Transformer 50 Amp. (480 V.).....	1
22	00-478962	Transformer (380-415 V.).....	1
23	FE-025-20	Fuse (0.2 Amp.).....	2
24	FE-025-58	Fuse (0.3 Amp.).....	1
25	SD-009-09	Self-Tapping Screw 8-32 x 1/2 Slotted Bndg. Hd., Type F.....	4
26	00-118544-00002	Lug - Grounding.....	1
27	SC-114-29	Mach. Screw 1/4-20 x 3/8 Phil. Pan Hd.....	1
28	WL-007-14	Lockwasher 1/4 External.....	1
29	00-087714-020-3	Relay (3.P.D.T.) (380-415/480 V.).....	1
30	SD-038-03	Self-Tapping Screw 10-16 x 3/4 Slotted Truss Hd., Type B (SST).....	2
31	00-294325-00021	Block - Terminal (4 Pole).....	1
32	SD-038-03	Self-Tapping Screw 10-16 x 3/4 Slotted Truss Hd., Type B (SST).....	2
33	00-479189-00001	Plate - Control Mounting (Weld).....	1
34	00-087714-046-2	Relay - 2 Pole (30 Amp.) (208 V.) (1 CR).....	1
35	00-087714-046-3	Relay - 2 Pole (30 Amp.) (240/480 V.) (1 CR).....	1
36	SD-009-09	Self-Tapping Screw 8-32 x 1/2 Slotted Bndg. Hd., Type F.....	2
37	00-937849	Contactora (2CR).....	1
38	SD-038-96	Self-Tapping Screw 6-32 x 1/2 Slotted Phil. Rd. Hd., Type F.....	2
39	00-916903-00002	Contactora (4-Pole) (3CON).....	1
40	SC-018-11	Mach. Screw 10-24 x 3/8 Slotted Pan Hd.....	2
41	WL-007-12	Lockwasher #10 External Shakeproof.....	2
42	00-477300-00002	Rail - Din.....	1
43	SC-018-11	Mach. Screw 10-24 x 3/8 Slotted Pan Hd.....	2
44	WL-007-12	Lockwasher #10 External Shakeproof.....	2
45	00-937848	Switch - Auxiliary.....	3
46	00-478220-00001	Heater (208 V.).....	1
47	00-478220-00002	Heater (240/480 V.).....	1
48	SC-018-11	Mach. Screw 10-24 x 3/8 Slotted Pan Hd.....	AR
49	WL-007-12	Lockwasher #10 External Shakeproof.....	AR

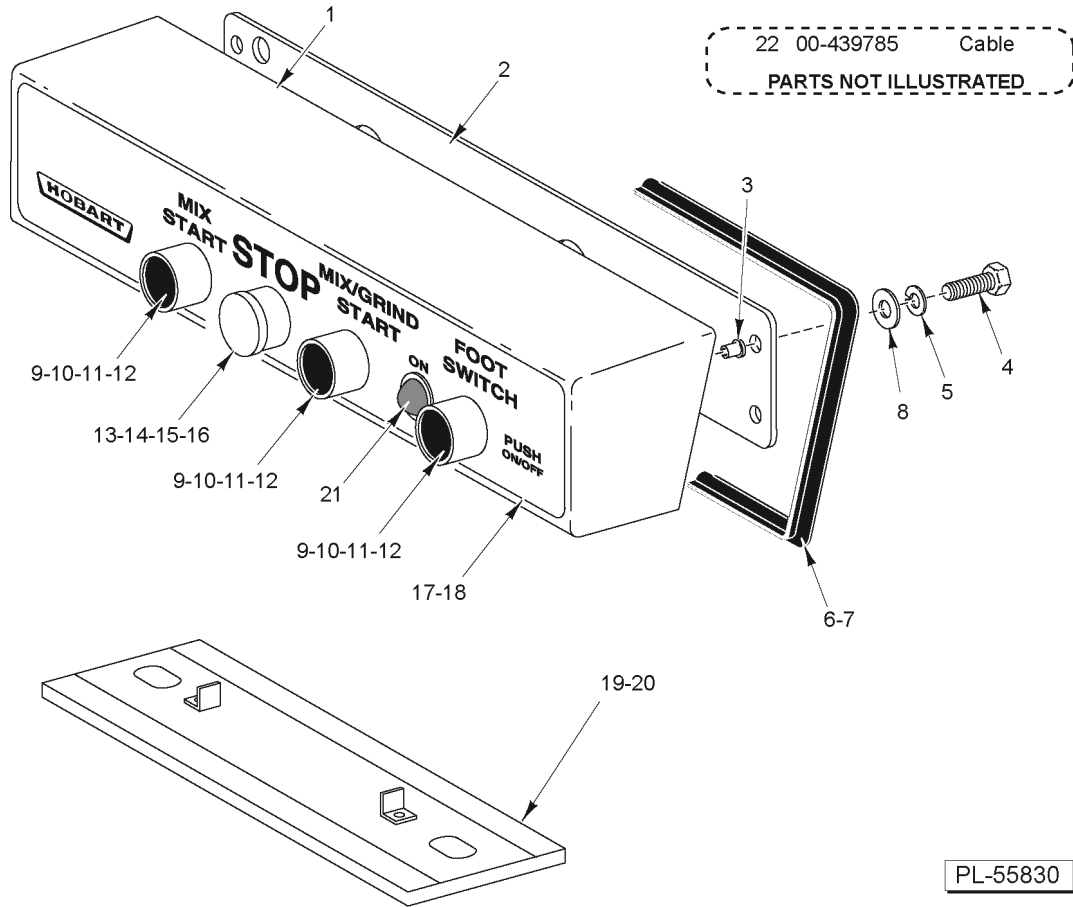

OPERATOR CONTROL PANEL

OPERATOR CONTROL PANEL

ILLUS.	PART NO.	NAME OF PART	AMT.
PL-55830			
1	00-479734	Box - Operator Control (Incls. Items 2, 4, 5, & 8).....	1
2	00-479630	Gasket.....	1
3	00-042648	Insert - Threaded.....	4
4	SC-067-08	Mach. Screw 10-24 x 7/8 Hex Hd. (SST).....	4
5	WL-006-07	Lockwasher #10 Helical (SST).....	4
6	00-102825-00006	Gasket - Housing (23-3/4 In.) (Order with 00-102825-00007).....	1
7	00-102825-00007	Gasket - Housing (12-3/4 In.) (Order with 00-102825-00006).....	1
8	WS-019-10	Washer (SST).....	4
9	00-913102-00195	Kit - Switch Operator & Block (Incls. Items 10 & 11).....	1
10	00-478752-00003	Switch - Operator.....	3
11	00-087711-322-3	Block - Contact.....	3
12	00-873427	Cap - Protective.....	3
13	00-913102-00194	Kit - Switch Operator & Block (Stop) (Incls. Items 14 & 15).....	1
14	00-478752-00008	Switch Assy. (Stop).....	1
15	00-087711-322-5	Block - Contact.....	1
16	00-873427-00002	Cap - Protective (Stop).....	1
17	00-479001	Panel - Trim (Canada).....	1
18	00-477930	Panel - Trim.....	1
19	00-478220-00002	Heater (240/480 V.).....	1
20	00-478220-00001	Heater (208 V.).....	1
21	00-477653-00002	Light - Pilot.....	1
22	00-439785	Cable.....	1

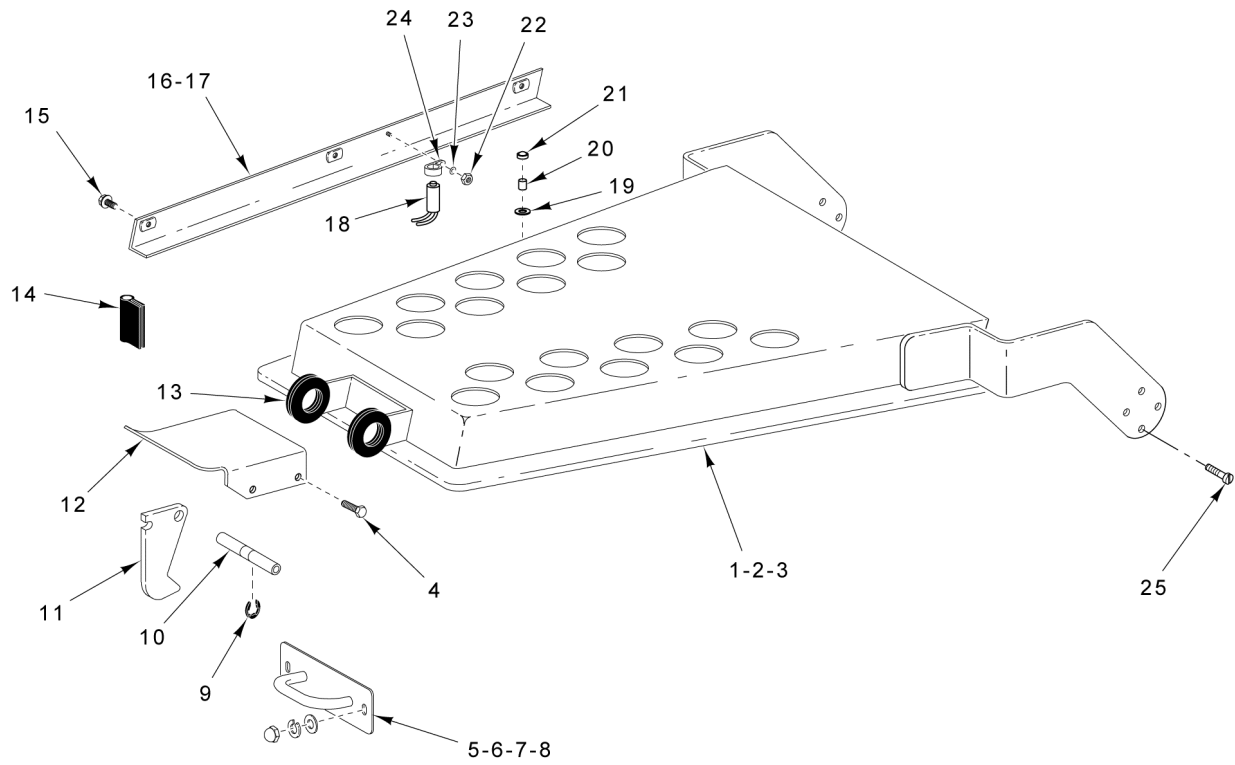

PL-55829

TOP COVER UNIT

TOP COVER UNIT

ILLUS. PL-55829	PART NO.	NAME OF PART	AMT.
1	00-946609-00001	Cover - Top Assy (MG1532) (Incls. Items 19, 20, & 21).....	1
2	00-946609-00002	Cover - Top Assy (MG2032) (Incls. Items 19, 20, & 21).....	1
3	00-478710	Cover - Top Assy. (MG2032) (Old Style with Hubs).....	1
4	SC-041-50	Cap Screw 1/4-20 x 1/2 Hex Hd. (SST).....	4
5	00-439822	Plate - Hasp.....	1
6	WS-017-06	Washer (SST).....	2
7	WL-006-17	Lockwasher 1/4 Helical (SST).....	2
8	NS-025-04	Crown Nut 1/4-20 (SST).....	2
9	RR-009-10	Retaining Ring 3/8 In. (SST).....	4
10	00-477928	Rod - Lid Latch.....	2
11	00-477927	Latch - Lid.....	1
12	00-477929	Handle - Lid Latch.....	1
13	00-477956	Grommet.....	2
14	00-102825-00005	Gasket - Housing (2 In.).....	2
15	SD-038-33	Self-Tapping Screw 10-24 x 1/2 Hex. Hex Washer Hd., Type TT.....	3
16	00-946608-00001	Wireway (MG1532) (Incls. Items 18, 22, 23, & 24).....	1
17	00-946608-00002	Wireway (MG2032) (Incls. Items 18, 22, 23, & 24).....	1
18	00-946633	Switch - Reed.....	1
19	00-946656	Seal - Lid Interlock.....	1
20	00-946607	Magnet.....	1
21	00-946606	Holder - Magnet.....	1
22	NS-009-22	Nut 10-24 Hex.....	1
23	WL-007-12	Lockwasher #10 External Shakeproof.....	1
24	00-078752-00003	Clamp - Cable.....	1
25	SC-053-17	Mach. Screw 5/16-18 x 3/4 Slotted Truss Hd. (SST).....	8

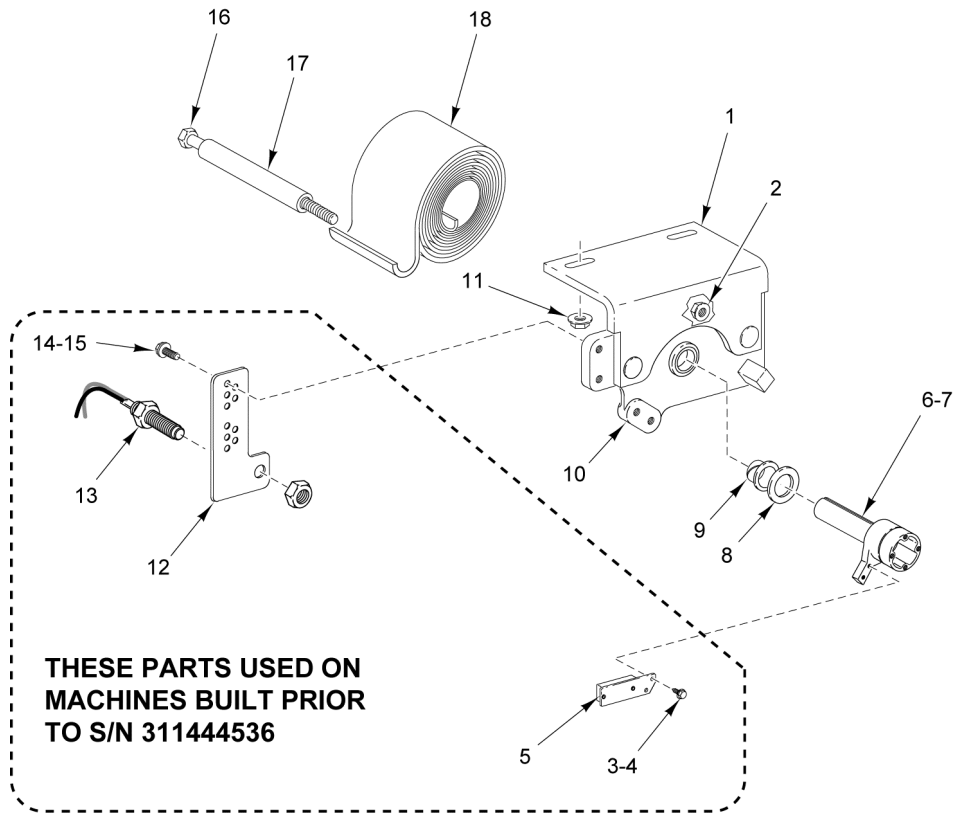

PL-55828

HINGE UNIT

HINGE UNIT

ILLUS.	PART NO.	NAME OF PART	AMT.
PL-55828			
1	00-478519	Bracket - Weldment.....	2
2	NS-038-11	Lock Nut 5/16-18 Flange.....	4
3	SC-113-96	Mach. Screw 8-32 x 1/2 Slotted Hex Washer Hd.....	2
4	WL-014-05	Lockwasher #8 External Shakeproof (SST).....	2
5	00-478523	Magnet Assy.....	1
6	00-478522-00002	Shaft - Hinge (LH).....	1
7	00-478522-00003	Shaft - Hinge (RH).....	1
8	WS-030-80	Washer.....	4
9	00-439845	Bearing - Sleeve.....	1
10	00-478518-00002	Block - Bearing.....	1
11	NS-038-11	Lock Nut 5/16-18 Flange.....	4
12	00-478520	Bracket - Switch.....	1
13	00-087711-307-1	Switch - Reed.....	1
14	SC-113-96	Mach. Screw 8-32 x 1/2 Slotted Hex Washer Hd.....	2
15	WL-014-05	Lockwasher #8 External Shakeproof (SST).....	2
16	SC-041-36	Cap Screw 3/8-16 x 2-1/2 Hex Hd. (SST).....	2
17	00-439774	Spacer - Hinge Spring.....	2
18	00-439838	Spring - Spiral Torsion.....	2

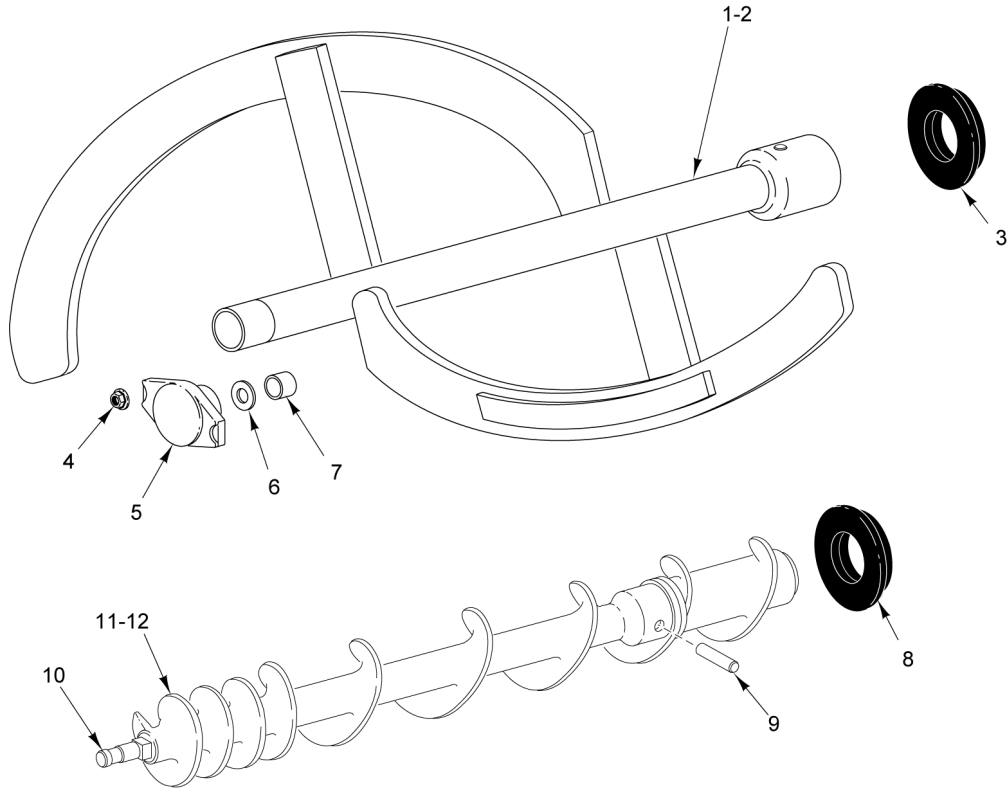

PL-56033

CONVEYOR AND MIXING ARM UNIT

CONVEYOR AND MIXING ARM UNIT

ILLUS.	PART NO.	NAME OF PART	AMT.
PL-56033			
1	00-479518	Mix Arm Assy. (MG2032).....	1
2	00-479517	Mix Arm Assy. (MG1532).....	1
3	00-479070	Seal (Mix Arm).....	1
4	NS-048-57	Nut 5/8-11 Flanged Hex.....	2
5	00-439763	Retainer Assy. (Incls. Items 6 & 7).....	1
6	00-186660	Washer - Thrust.....	1
7	00-186659	Bearing - Pilot Bushing.....	1
8	00-479070	Seal (Conveyor Assy.).....	1
9	00-477960	Pin - Shear.....	1
10	00-110576	Stud - Plate.....	1
11	00-968058	Conveyor Assy. (Cast) (MG2032) (Incls. Item 10).....	1
12	00-968057	Conveyor Assy. (Cast) (MG1532) (Incls. Item 10).....	1

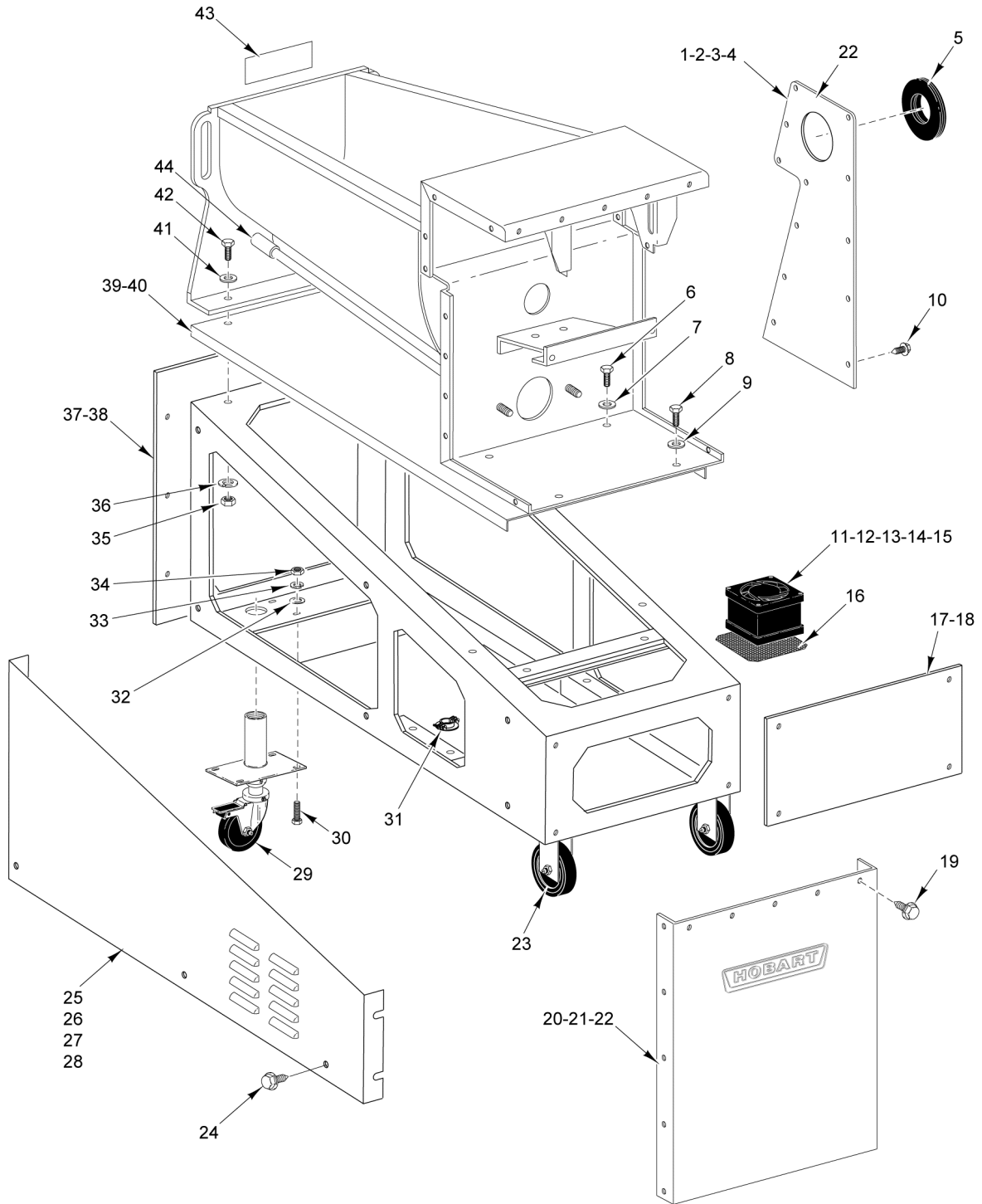

PL-55827

FRAME AND HOPPER UNIT

FRAME AND HOPPER UNIT

ILLUS.	PART NO.	NAME OF PART	AMT.
PL-55827			
1	00-478728-00001	Panel - Upper Side (LH) (MG2032).....	1
2	00-478728-00002	Panel - Upper Side (RH) (MG2032).....	1
3	00-439826-00001	Panel - Upper Side (LH) (MG1532).....	1
4	00-439826-00002	Panel - Upper Side (RH) (MG1532).....	1
5	00-439835	Seal.....	2
6	SC-041-31	Cap Screw 3/8-16 x 1-1/4 Hex Hd. (SST).....	2
7	WS-018-04	Washer (SST).....	2
8	SC-041-31	Cap Screw 3/8-16 x 1-1/4 Hex Hd. (SST).....	2
9	WS-018-04	Washer (SST).....	2
10	SD-038-33	Self-Tapping Screw 10-24 x 1/2 Hex. Hex Washer Hd., Type TT.....	12
11	00-478738-00001	Fan - Cooling (230 V.).....	1
12	00-294853-026-1	Cable - Fan (240 V.).....	1
13	00-294853-026-2	Cable - Fan (480 V.).....	1
14	SC-119-30	Mach. Screw 6-32 x 3/4 Hex Hd. (SST).....	4
15	NS-031-50	Stop Nut 6-32 Hex (SST).....	4
16	00-478737	Panel - Perforated.....	1
17	00-439828-00003	Panel - Back (MG2032).....	1
18	00-439828-00002	Panel - Back (MG1532).....	1
19	SD-038-33	Self-Tapping Screw 10-24 x 1/2 Hex. Hex Washer Hd., Type TT.....	5
20	00-439824-00003	Panel - Upper Back (MG2032).....	1
21	00-439824-00002	Panel - Upper Back (MG1532).....	1
22	00-557188	Foam - Tape (0.187 Thk. x 0.500 Wide) (50 Ft. Roll).....	1
23	00-439787	Caster - Fixed.....	2
24	SD-038-33	Self-Tapping Screw 10-24 x 1/2 Hex. Hex Washer Hd., Type TT.....	6
25	00-478718-00001	Panel - Lower Side (LH) (MG2032).....	1
26	00-478718-00002	Panel - Lower Side (RH) (MG2032).....	1
27	00-439829-00001	Panel - Lower Side (LH) (MG1532).....	1
28	00-439829-00002	Panel - Lower Side (RH) (MG1532).....	1
29	00-477924	Caster - Assembly 4 In. Swivel.....	2
30	SC-037-85	Cap Screw 5/16-18 x 1 Hex Hd.....	16
31	FE-023-47	Strain Relief - Electrical (1 In.).....	1
32	WS-005-32	Washer (SST).....	32
33	WL-003-47	Lockwasher 5/16 Helical.....	16
34	NS-013-14	Nut 5/16-18 Hex.....	16
35	NS-015-13	Nut 3/8-16 Hex (SST).....	3
36	WL-006-28	Lockwasher 3/8 Helical (SST).....	3
37	00-478719	Panel - Front (MG2032).....	1
38	00-439827	Panel - Front (MG1532).....	1
39	00-478706	Tablecloth (MG2032).....	1
40	00-478705	Tablecloth (MG1532).....	1
41	WS-018-04	Washer (SST).....	3
42	SC-041-31	Cap Screw 3/8-16 x 1-1/4 Hex Hd. (SST).....	3
43	00-438131-00086	Label - Warning.....	1
44	00-118250	Coupling.....	2

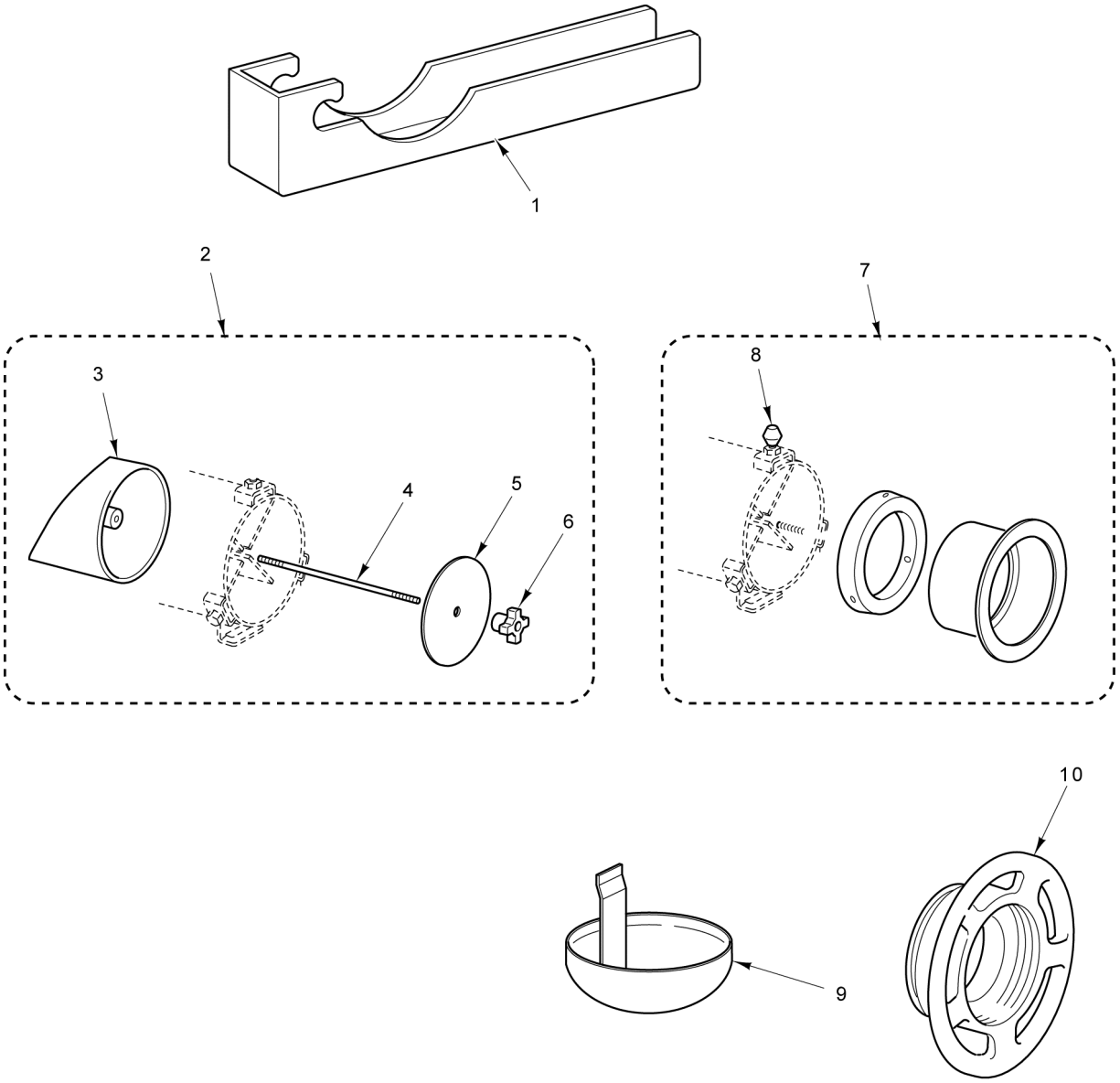

- | | | |
|----|-----------|----------------------|
| 11 | 00-873440 | Adapter (Hollymatic) |
| 12 | 00-478649 | Side Board |
- PARTS NOT ILLUSTRATED**

PL-60506

ACCESSORIES

ACCESSORIES

ILLUS.	PART NO.	NAME OF PART	AMT.
PL-60506			
1	ML-109640-0000Z	Drain Pan.....	1
2	00-477983	Plug Assy. (Side Feed Hopper) (Incls. Items 3 thru 6).....	1
3	00-477982	Plug & Stud (Incls. Item 4).....	1
4	00-186755-00002	Rod - Tie.....	1
5	00-186890	Cap - Hopper Feed.....	1
6	00-292420	Knob Assy.....	1
7	00-873537	Adapter Assy.....	AR
8	00-108197-00008	Thumb Screw (2-9/16 In. Lg.).....	3
9	00-295109	Dripping Cup Assy.....	1
10	00-080879-00002	Ring - Adapter (Packaged).....	1
11	00-873440	Adapter - Bulker (For Hollymatic).....	1
12	00-478649	Side Board.....	1

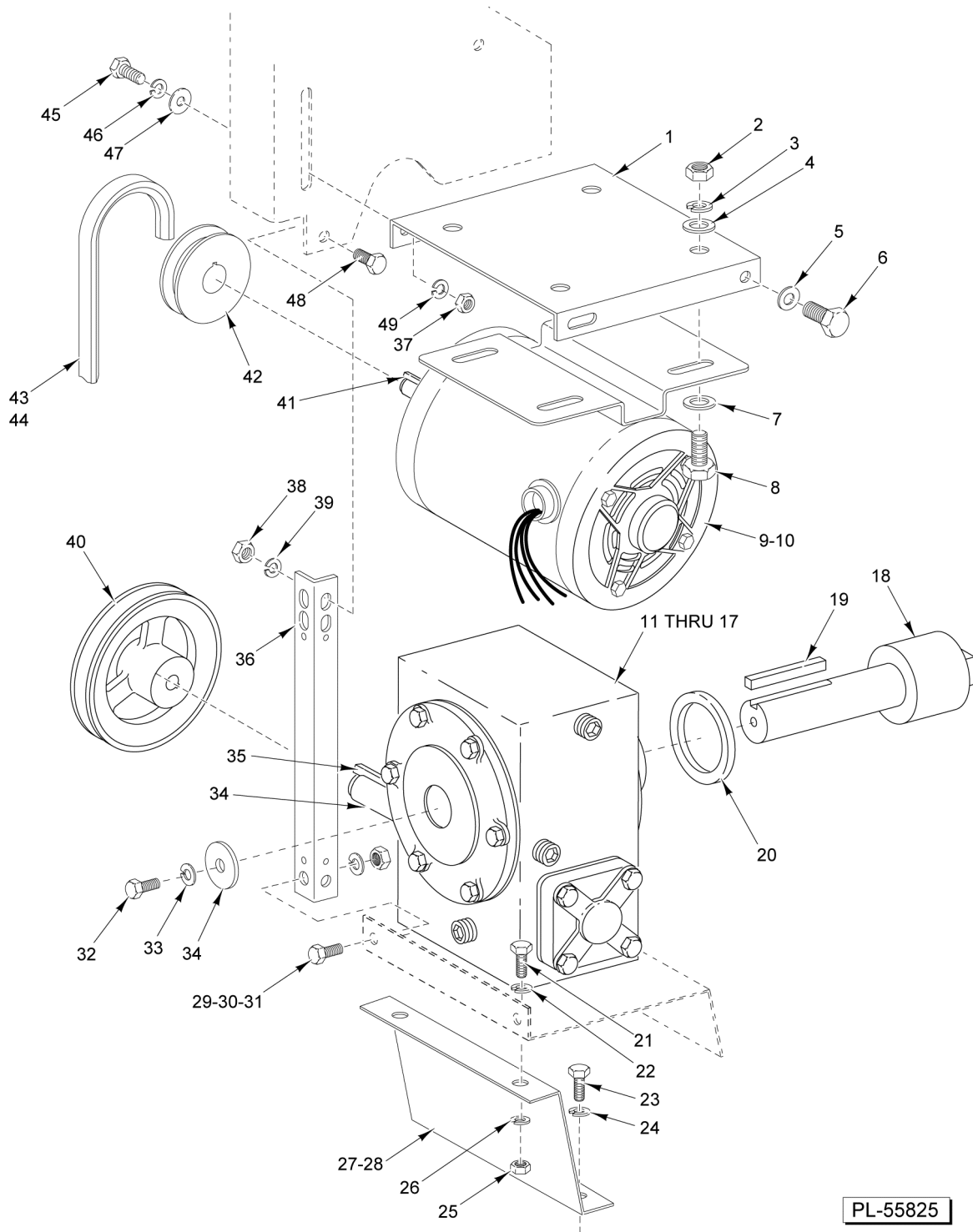

PL-55825

MIX MOTOR UNIT

MIX MOTOR UNIT

ILLUS.	PART NO.	NAME OF PART	AMT.
PL-55825			
1	00-873266	Bracket - Nut (Mix Motor).....	1
2	NS-013-14	Nut 5/16-18 Hex.....	4
3	WL-006-23	Lockwasher 5/16 Helical (SST).....	4
4	WS-005-39	Washer (SST).....	4
5	WL-006-28	Lockwasher 3/8 Helical (SST).....	2
6	SC-118-12	Cap Screw 3/8-16 x 3/4 Hex Hd.....	2
7	WS-005-39	Washer (SST).....	4
8	SC-037-85	Cap Screw 5/16-18 x 1 Hex Hd.....	4
9	00-435805-00002	Motor Assy. (208-240/480 V., 60 Hz., 3 Ph., 1 Hp.).....	1
10	00-435806-00002	Motor Assy. (208-240/60/1).....	1
11	00-186696	Gear Reducer.....	1
12	SC-118-12	Cap Screw 3/8-16 x 3/4 Hex Hd. (Used to mount Item 10).....	4
13	WL-006-28	Lockwasher 3/8 Helical (SST) (Used to mount Item 10).....	4
14	00-186646-00001	Shim (0.120 Thk.).....	AR
15	00-186646-00002	Shim (0.060 Thk.).....	AR
16	00-186646-00003	Shim (0.030 Thk.).....	AR
17	00-186646-00004	Shim (0.018 Thk.).....	AR
18	00-439743	Shaft - Mix Arm (Sq. Drive).....	1
19	00-012430-00196	Key 1/4 x 1/4 x 4-3/4.....	1
20	WS-014-37	Washer.....	AR
21	SC-041-12	Cap Screw 5/16-18 x 7/8 Hex Hd. (SST).....	2
22	WL-006-23	Lockwasher 5/16 Helical (SST).....	2
23	SC-118-12	Cap Screw 3/8-16 x 3/4 Hex Hd.....	2
24	WL-006-28	Lockwasher 3/8 Helical (SST).....	2
25	NS-013-14	Nut 5/16-18 Hex.....	2
26	WL-006-23	Lockwasher 5/16 Helical (SST).....	2
27	00-479236	Brace - Mix/Grind (MG1532).....	1
28	00-479237	Brace - Mix/Grind (MG2032).....	1
29	SC-041-12	Cap Screw 5/16-18 x 7/8 Hex Hd. (SST).....	2
30	WL-006-23	Lockwasher 5/16 Helical (SST).....	2
31	NS-013-14	Nut 5/16-18 Hex.....	2
32	SC-062-22	Cap Screw 3/8-16 x 1-1/4 Hex Hd.....	1
33	WL-006-28	Lockwasher 3/8 Helical (SST).....	1
34	00-186703	Washer.....	1
35	00-012430-00067	Key 3/16 x 1 1/2.....	1
36	00-873330	NLA - Obsolete--Brace - Mix Drive.....	2
37	NS-013-14	Nut 5/16-18 Hex.....	4
38	NS-013-14	Nut 5/16-18 Hex.....	2
39	WL-006-23	Lockwasher 5/16 Helical (SST).....	2
40	00-479801	Pulley - Mix Arm Transmission.....	1
41	00-012430-00091	Key 3/16 x 3/16 x 1 3/8.....	1
42	00-479800	Pulley, Mix Arm Motor.....	1
43	BV-013-32	V-Belt (MG1532).....	1
44	BV-013-39	V-Belt (MG2032).....	1
45	SC-118-12	Cap Screw 3/8-16 x 3/4 Hex Hd.....	2
46	WL-006-23	Lockwasher 5/16 Helical (SST).....	2
47	WS-018-04	Washer (SST).....	2
48	SC-041-12	Cap Screw 5/16-18 x 7/8 Hex Hd. (SST).....	2
49	WL-006-23	Lockwasher 5/16 Helical (SST).....	4

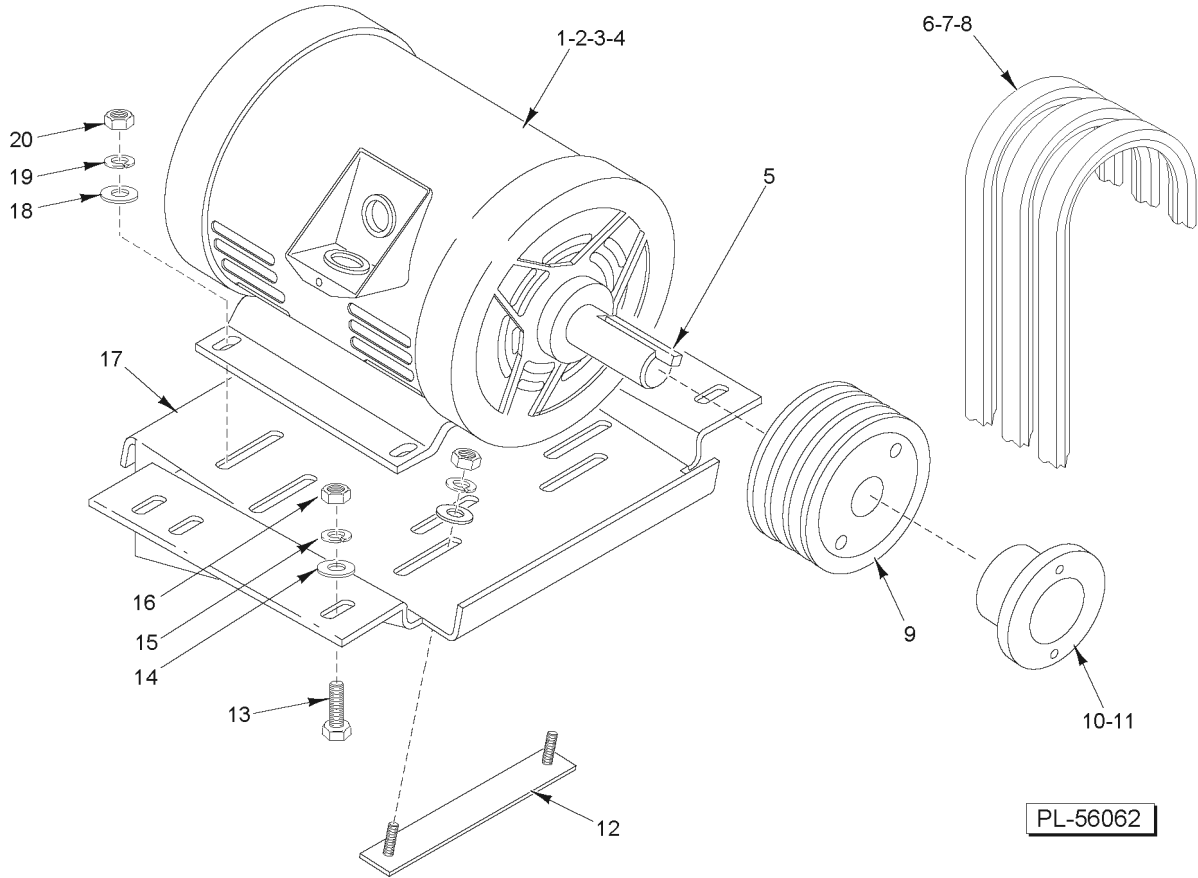

GRIND MOTOR UNIT

GRIND MOTOR UNIT

ILLUS.	PART NO.	NAME OF PART	AMT.
PL-56062			
1	00-435697-00003	Motor - Grind (208 V., 60 Hz., 3 Ph., 7-1/2 Hp.).....	1
2	00-435697-00002	Motor - Grind (230/460V., 50/60 Hz., 3 Ph., 7.5 Hp.) (Must Also Order Item 3).....	1
3	00-065890-00018	Terminal.....	9
4	01-650122-00002	Motor - Grind 5HP (1 Ph.), Assy.....	1
5	00-012430-00106	Key 3/16 x 5/16 x 1-1/4 (7-1/2 Hp.).....	1
6	BV-013-41	V-Belt (380-415/50/3 Only).....	3
7	BV-013-38	V-Belt (3 Ph., Except 380-415/50/3).....	3
8	BV-013-37	V-Belt (1 Ph.).....	3
9	00-479613-00001	Pulley - Grind Motor.....	1
10	00-479613-00002	Pulley - Hub (7-1/2 Hp.).....	1
11	00-479613-00003	Pulley - Hub (5 Hp.).....	1
12	00-479064	Stud & Plate.....	2
13	SC-118-09	Cap Screw 3/8-16 x 1-1/4 Hex Hd.....	4
14	WS-030-05	Washer (SST).....	4
15	WL-006-28	Lockwasher 3/8 Helical (SST).....	4
16	NS-047-39	Nut 3/8-16 Hex (Grade 5).....	4
17	00-478704	Bracket - Grind Motor.....	1
18	WS-030-05	Washer (SST).....	4
19	NS-047-39	Nut 3/8-16 Hex (Grade 5).....	4
20	WL-006-28	Lockwasher 3/8 Helical (SST).....	4

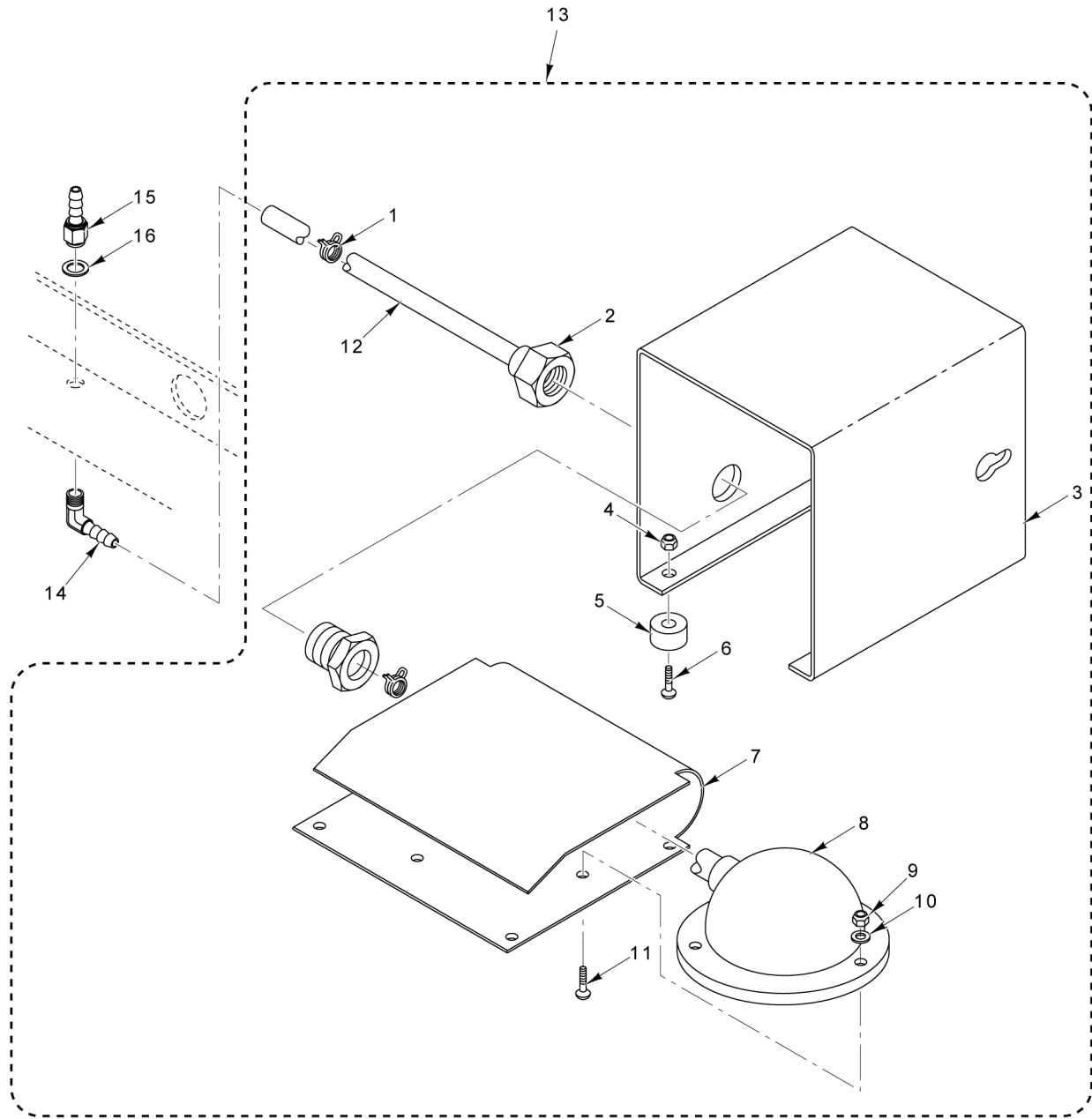

PL-55826

FOOT SWITCH UNIT (PNEUMATIC)

FOOT SWITCH UNIT (PNEUMATIC)

ILLUS.	PART NO.	NAME OF PART	AMT.
PL-55826			
1	00-115747-00009	Clamp - Hose.....	2
2	FE-024-11	Strain Relief.....	1
3	00-875782	Cover - Foot Switch.....	1
4	NS-031-08	Stop Nut 8-32 Special (SST).....	4
5	00-019105-00002	Bumper.....	4
6	SC-021-89	Mach. Screw 8-32 x 5/8 Slotted Rd. Hd. (SST).....	4
7	00-875783	NLA - Obsolete--Pedal - Foot Switch.....	1
8	00-087711-214-1	Actuator - Air Switch.....	1
9	NS-031-08	Stop Nut 8-32 Special (SST).....	3
10	WS-023-44	Washer (SST).....	3
11	SC-021-15	Mach. Screw 8-32 x 1/2 Slotted Rd. Hd. (SST).....	3
12	00-946676	Tubing & Clamp Assy. (66 In.).....	1
13	00-875785	Foot Switch Assy. (Incls. Items 1 thru 12).....	1
14	FP-075-75	Fitting - Hose Male Elbow 3/16.....	1
15	FP-075-76	Fitting - Hose Female 3/16.....	1
16	WS-018-37	Washer (SST) (.406 x .813 x .080).....	1

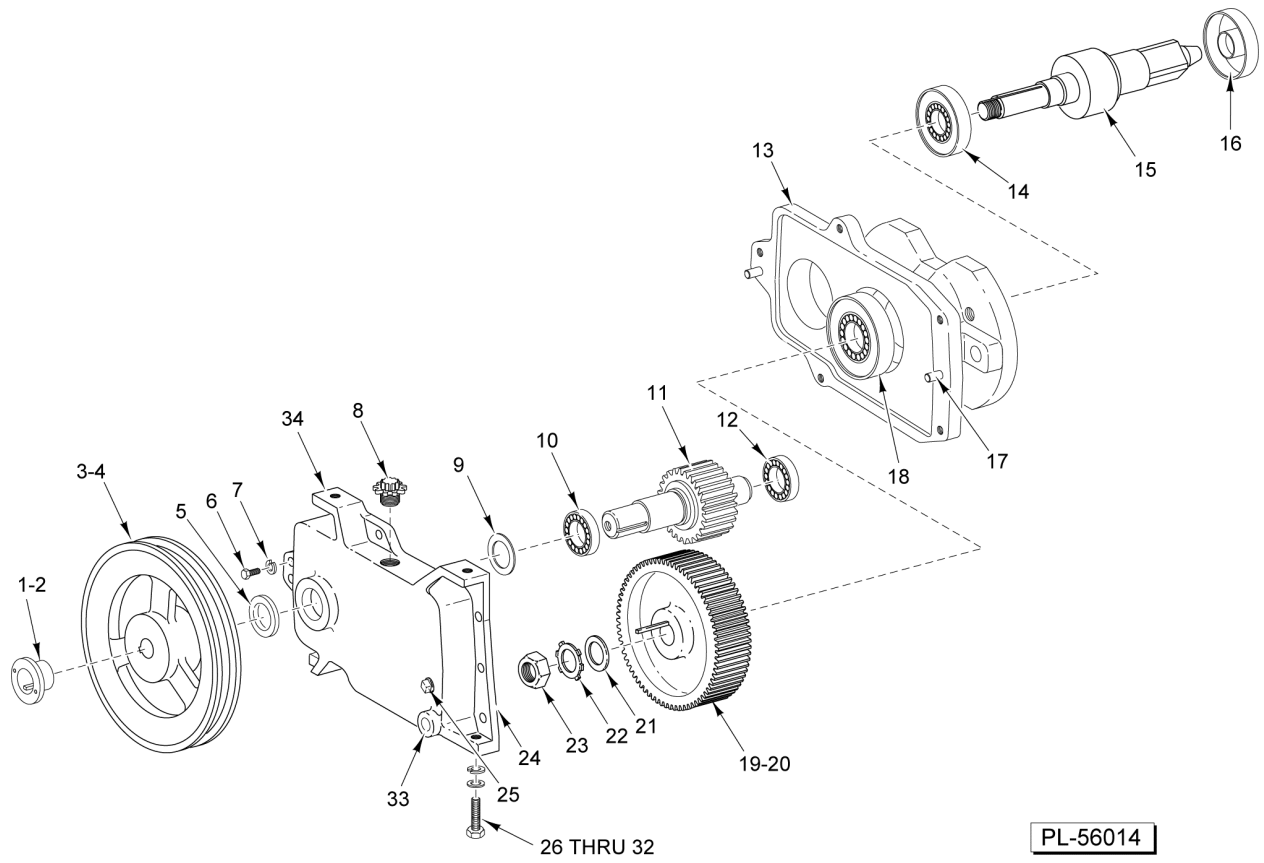

TRANSMISSION UNIT

TRANSMISSION UNIT

ILLUS. PL-56014	PART NO.	NAME OF PART	AMT.
1	00-479615-00002	Hub.....	1
2	00-012430-00178	Key 1/4 x 1/4 x 1-1/2.....	1
3	00-479615-00001	Pulley - Transmission.....	1
4	00-479807-00001	Pulley - Transmission (50 Hz.).....	1
5	00-968048	Seal - Oil.....	1
6	SC-062-22	Cap Screw 3/8-16 x 1-1/4 Hex Hd.....	5
7	WL-006-28	Lockwasher 3/8 Helical (SST).....	5
8	00-108963-00002	Plug - Oil Fill.....	1
9	SL-003-11	Spring - Loading ND 72.....	1
10	BB-007-21	Ball Bearing - N.D. 3207.....	1
11	00-477940	Shaft - Pinion (18T).....	1
12	BB-018-33	Ball Bearing - Fafnir #205KFA.....	1
13	00-873490	Hub Attachment.....	1
14	BR-002-28	Roller Bearing - Cone & Cup Assy.....	1
15	00-439742	Shaft - Grind Worm Drive.....	1
16	00-108591	Seal.....	1
17	00-508199	Pin - Dowel (Mach.).....	2
18	BR-002-20	Roller Bearing - Cup & Cone Assy.....	1
19	00-477939	Gear (57T).....	1
20	00-012430-00215	Key.....	1
21	WS-031-36	Washer.....	1
22	WL-017-07	Lockwasher - Bearing Lock Nut.....	1
23	NS-034-07	Lock Nut N.D. #N-06.....	1
24	00-873484	Kit - Gear Case.....	1
25	FP-028-42	Plug - Pipe 1/8.....	1
26	SC-062-22	Cap Screw 3/8-16 x 1-1/4 Hex Hd.....	2
27	WL-006-28	Lockwasher 3/8 Helical (SST).....	2
28	WS-018-04	Washer (SST).....	2
29	00-186646-00001	Shim (0.120 Thk.).....	AR
30	00-186646-00002	Shim (0.060 Thk.).....	AR
31	00-186646-00003	Shim (0.030 Thk.).....	AR
32	00-186646-00004	Shim (0.018 Thk.).....	AR
33	FP-028-38	Plug - Pipe 3/8.....	1
34	00-873491	Transmission Assy. (Incls. Items 5 thru 25 & 33).....	1

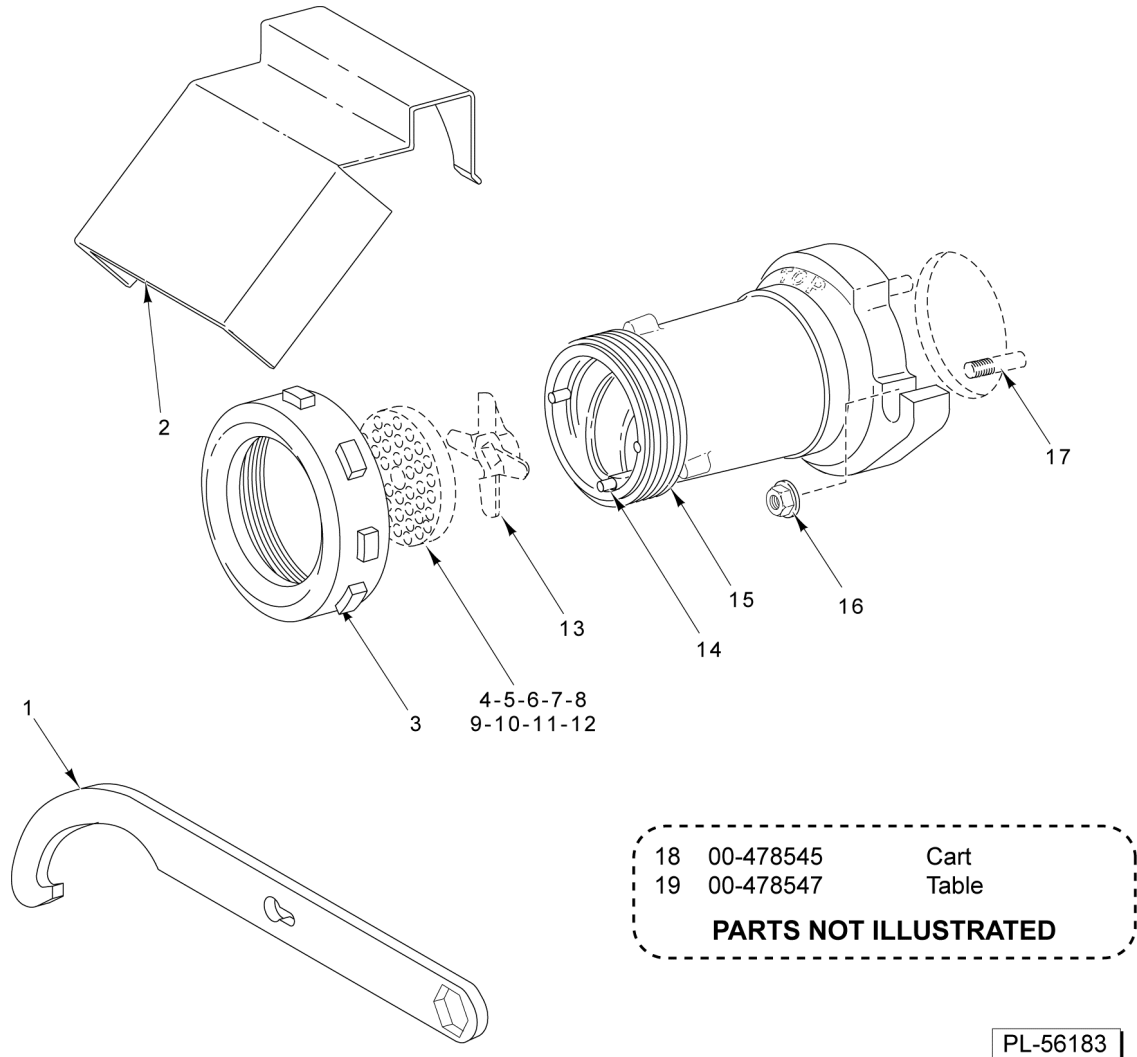

PL-56183

#32 GRINDER UNIT

#32 GRINDER UNIT

ILLUS.	PART NO.	NAME OF PART	AMT.
PL-56183			
1	00-873570	Wrench - Cylinder.....	1
2	00-875250	Meat Deflector (Packaged).....	1
3	00-873697	Ring - Adjusting.....	1
4	00-015857-00001	Plate #32 (5/64) (Carbon Steel).....	AR
5	00-108580-00001	Plate #32 (1/8) (Carbon Steel).....	AR
6	00-108580-00002	Plate #32 (1/8) (Stay Sharp).....	AR
7	00-108581-00001	Plate #32 (3/16) (Carbon Steel).....	AR
8	00-108581-00002	Plate #32 (3/16) (Stay Sharp).....	AR
9	00-108582-00001	Plate #32 (1/4) (Carbon Steel).....	AR
10	00-108582-00002	Plate #32 (1/4) (Stay Sharp).....	AR
11	00-108583-00001	Plate #32 (3/8) (Carbon Steel).....	AR
12	00-108583-00002	Plate #32 (3/8) (Stay Sharp).....	AR
13	00-479257	Knife #32 (Stay Sharp).....	AR
14	00-105806	Pin - Plate.....	1
15	00-873720-00002	Cylinder #32 (Mach. SST).....	1
16	NS-048-57	Nut 5/8-11 Flanged Hex.....	2
17	00-118266	Stud.....	2
18	00-478545	Cart.....	1
19	00-478547	Table - Split Level.....	1

