

VULCAN

CATALOG OF REPLACEMENT PARTS

GRD & GRC SERIES GAS FRYER With KleenScreen PLUS® Filtration Systems

MODEL	ML NUMBER	PRIOR MLS COVERED IN THIS MANUAL	
		MODEL	ML NUMBER
2GR45DF	ML-136424	2GR45MF	ML-136417
2GR65DF	ML-136425	2GR65MF	ML-136418
2GR85DF	ML-136426	2GR85MF	ML-136419
3GR45DF	ML-136427	3GR45MF	ML-136420
3GR65DF	ML-136428	3GR65MF	ML-136421
3GR85DF	ML-136429	3GR85MF	ML-136422
4GR45DF	ML-136430	4GR45MF	ML-136423
4GR65DF	ML-136662		
4GR85DF	ML-136665		
2GR45CF	ML-136431		
2GR65CF	ML-136432		
2GR85CF	ML-136433		
3GR45CF	ML-136434		
3GR65CF	ML-136435		
3GR85CF	ML-136436		
4GR45CF	ML-136437		
4GR65CF	ML-136663		
4GR85CF	ML-136666		
2XG45DF	ML-136562		
2XG65DF	ML-136638		
2XG85DF	ML-136565		
2XG45CF	ML-136563		
2XG65CF	ML-136639		
2XG85CF	ML-136566		



For additional information on Vulcan-Hart Company or to locate an authorized parts and service provider in your area, visit our website at www.vulcanhart.com

Table Of Contents

3	CONTROL PANEL (NCC)
5	POWER SUPPLY BOX
7	BODY UNIT (GRCF & GRDF SERIES)
9	BODY UNIT (GRMF SERIES)
11	BURNER COMPONENTS (GRCF & GRDF SERIES)
13	BURNER COMPONENTS (GRMF SERIES)
14	GAS VALVE (GRCF & GRDF SERIES) (PREVIOUS CONSTRUCTION)
15	GAS VALVE (GRCF & GRDF SERIES) (CURRENT CONSTRUCTION)
16	GAS VALVE (GRMF SERIES) (PREVIOUS CONSTRUCTION)
17	GAS VALVE (GRMF SERIES) (CURRENT CONSTRUCTION)
19	TANK AND DRAIN
21	OIL RETURN (GRCF AND GRDF SERIES)
22	OIL RETURN (GR45MF)
24	OIL RETURN (GR65MF AND GR85MF)
27	FILTER ASSEMBLY (PREVIOUS CONSTRUCTION)
29	FILTER ASSEMBLY (CURRENT CONSTRUCTION)
31	GAS INLET MANIFOLD

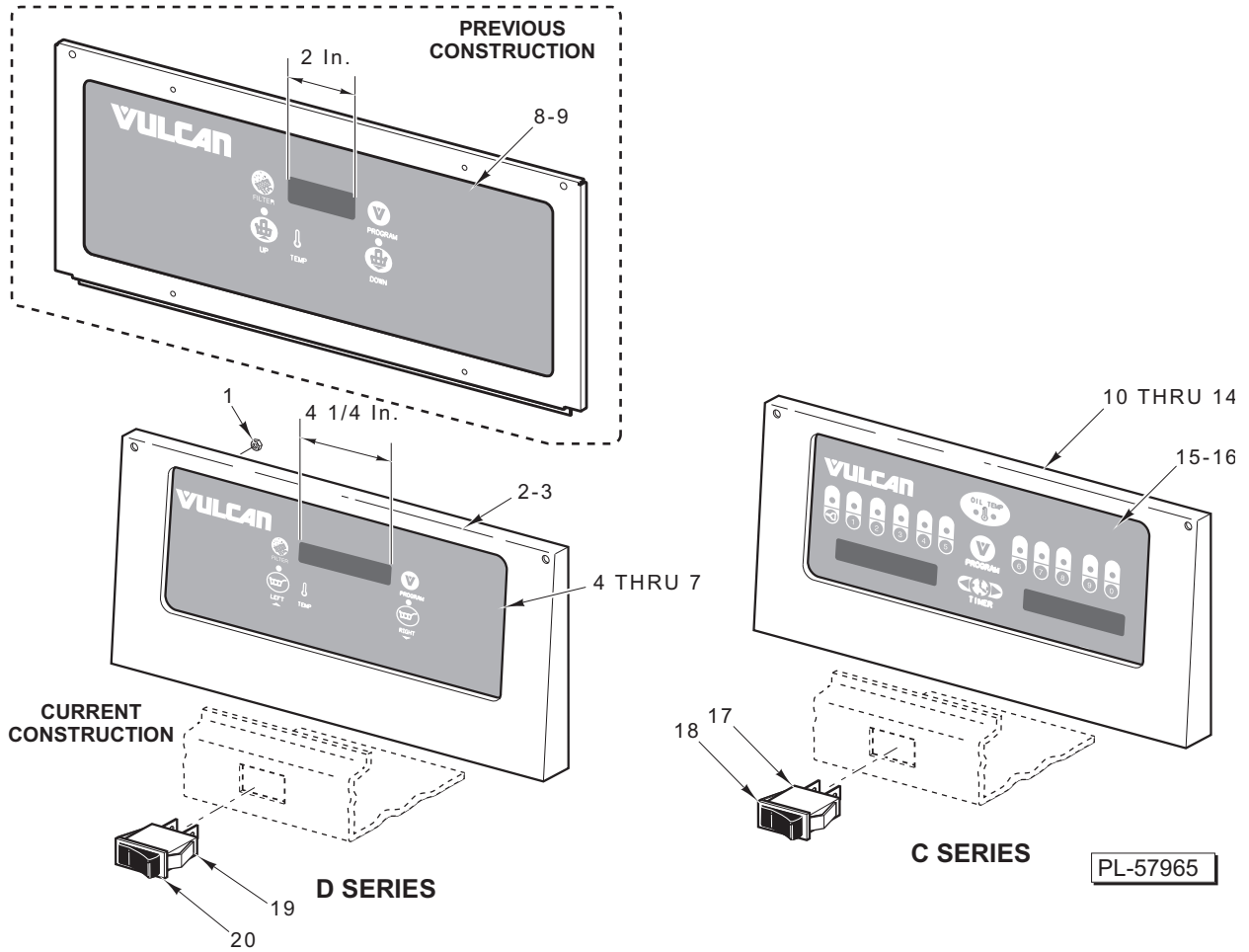

CONTROL PANEL (NCC)

ILLUS.	PART NO.	NAME OF PART	AMT.
	PL-57965		
1	NS-046-89	Nut Assy. 6-32 Hex	4
2	00-426815-000G1	Plate Assy. – Mounting (GR45DF).....	1
3	00-426815-000G2	Plate Assy. – Mounting (GR65/85DF).....	1
4	00-497745-00001	Overlay – Vulcan (Filter).....	1
5	00-497745-00003	Overlay – Vulcan (Boil).....	1
6	00-913086-00004	Control Assy. – Solid State (Filter Button) (Incls. Item 4).....	1
7	00-913086-00003	Control Assy. – Solid State (Boil Button) (Incls. Item 5).....	1
8	00-426815-00001	Overlay – Control Panel (Filter Button).....	1
9	00-497421-00001	Overlay – Control Panel (Boil Button).....	1
10	00-913086-00002	Computer Cooking Assy. (Filter Button) (Incls. Item 15).....	1
11	00-913086-00001	Computer Cooking Assy. (Boil Button) (Incls. Item 16).....	1
12	00-426815-000G1	Plate Assy. – Mounting (GR45CF).....	1
13	00-426815-000G2	Plate Assy. – Mounting (GR65/85CF).....	1
14	NS-046-89	Nut Assy. 6-32 Hex	4
15	00-426732-00001	Overlay – Control Panel (Filter Button).....	1
16	00-497422-00001	Overlay – Control Panel (Boil Button).....	1
17	00-427755-000G1	Switch Assy. – Power.....	1
18	00-428906-00001	Overlay – Power	1
19	00-427755-000G1	Switch Assy. – Power.....	1
20	00-428906-00001	Overlay – Power	1

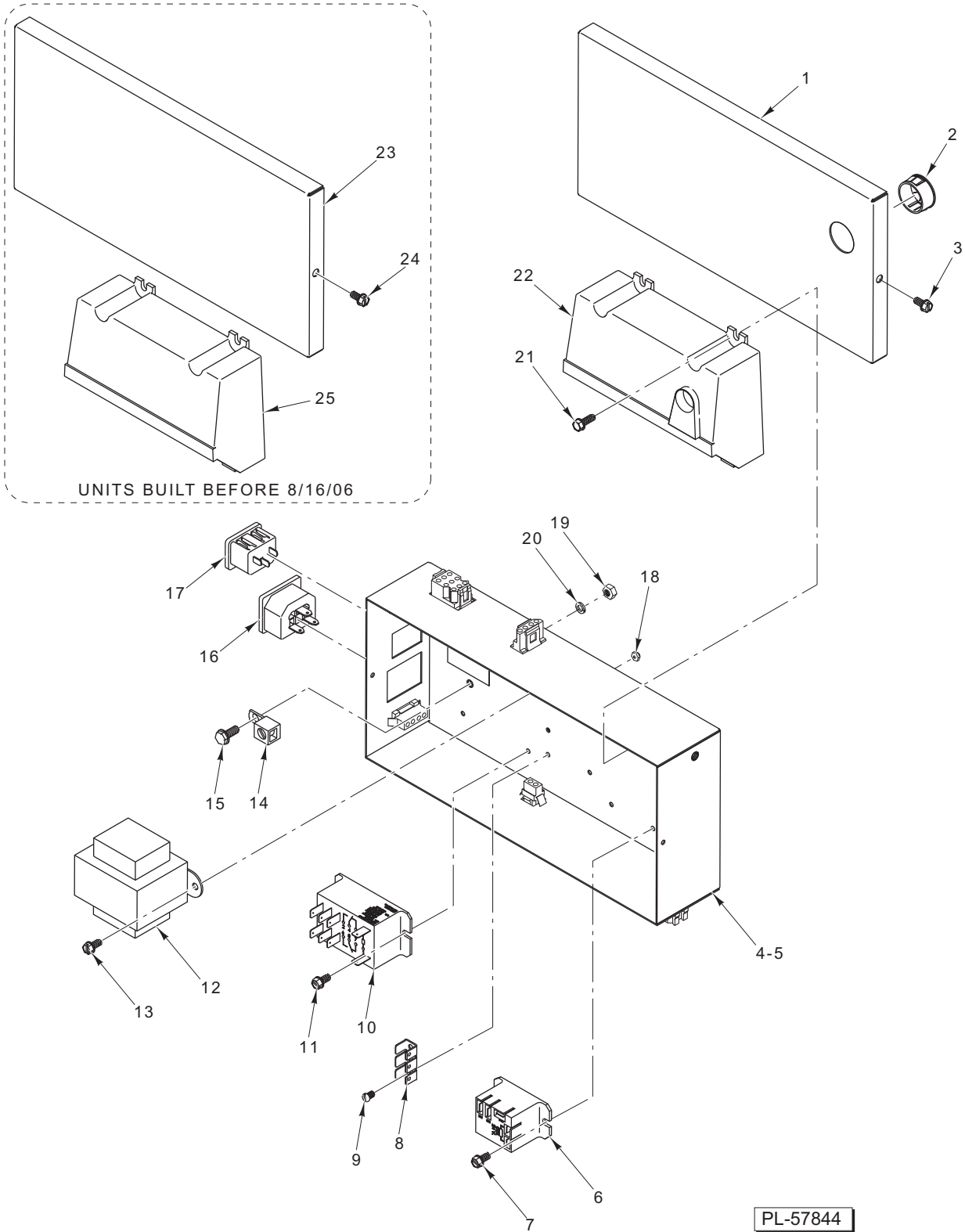

POWER SUPPLY BOX

POWER SUPPLY BOX

ILLUS.	PART NO.	NAME OF PART	AMT.
	PL-57844		
1	00-428684-00002	Lid – Power Supply (Machines Built After 8/16/06).....	1
2	FE-024-24	Bushing – Electrical Snap.....	1
3	SD-036-03	Self-Tapping Screw 8-18 x 3/8 Hex Washer Hd., Type AB.....	2
4	00-428716-000G1	Box – Power Supply (Filter).....	1
5	00-428716-000G2	Box – Power Supply (120 V.) (Non-Filter).....	1
6	00-497125-00001	Relay S.P.D.T. (24 VAC) (Battery Units) (Filter).....	1
7	SD-036-03	Self-Tapping Screw 8-18 x 3/8 Hex Washer Hd., Type AB (Battery Units).....	2
8	00-419317	Lug – Terminal.....	1
9	SC-060-23	Mach. Screw 4-40 x 1/4 Slotted Rd. Hd.	2
10	00-428864-00001	Relay (Battery Units).....	1
11	SD-036-03	Self-Tapping Screw 8-18 x 3/8 Hex Washer Hd., Type AB (Battery Units).....	2
12	00-411500-00012	Transformer (120 V.-24 V., 40 VA).....	1
13	SD-036-03	Self-Tapping Screw 8-18 x 3/8 Hex Washer Hd., Type AB.....	2
14	00-417856-00001	Lug – Ground.....	1
15	SD-032-07	Self-Tapping Screw 10-24 x 1/2 Hex Washer Hd., Type TT.....	1
16	00-419973-000G2	Receptacle – Female Power (Battery Units).....	1
17	00-419973-000G1	Receptacle – Male Power.....	1
18	NS-047-32	Lock Nut 4-40 Hex.....	2
19	NS-044-09	Nut Assy. 10-24 Hex KEPS.....	1
20	WL-004-40	Lockwasher #10 Helical.....	1
21	SD-037-49	Self-Tapping Screw 8-18 x 1/2 Hex Washer Hd., Type AB.....	4
22	00-857207-00001	Module – Ignition (Machines Built After 8/16/06).....	1
23	00-428684-00001	Lid – Power Supply Box (Battery Units) (Machines Built On Or Before 8/16/06).....	1
24	SD-036-03	Self-Tapping Screw 8-18 x 3/8 Hex Washer Hd., Type AB (Battery Units).....	2
*25	-	Module – Ignition (Machines With Electronic Ignition) (Machines Built On Or Before 8/16/06).....	1
	00-428685-000G2	Box – Power Supply (With Filtration) (Incls. Items 1 thru 4 & 6 thru24).....	1
	00-428685-000G5	Box – Power Supply (Without Filtration) (Incls. Items 1, 2, 3, 5, 7, 8, 9, 11, 12 thru 15, & 17 thru 24).....	1

* Order items 1, 2, & 22 when replacing.

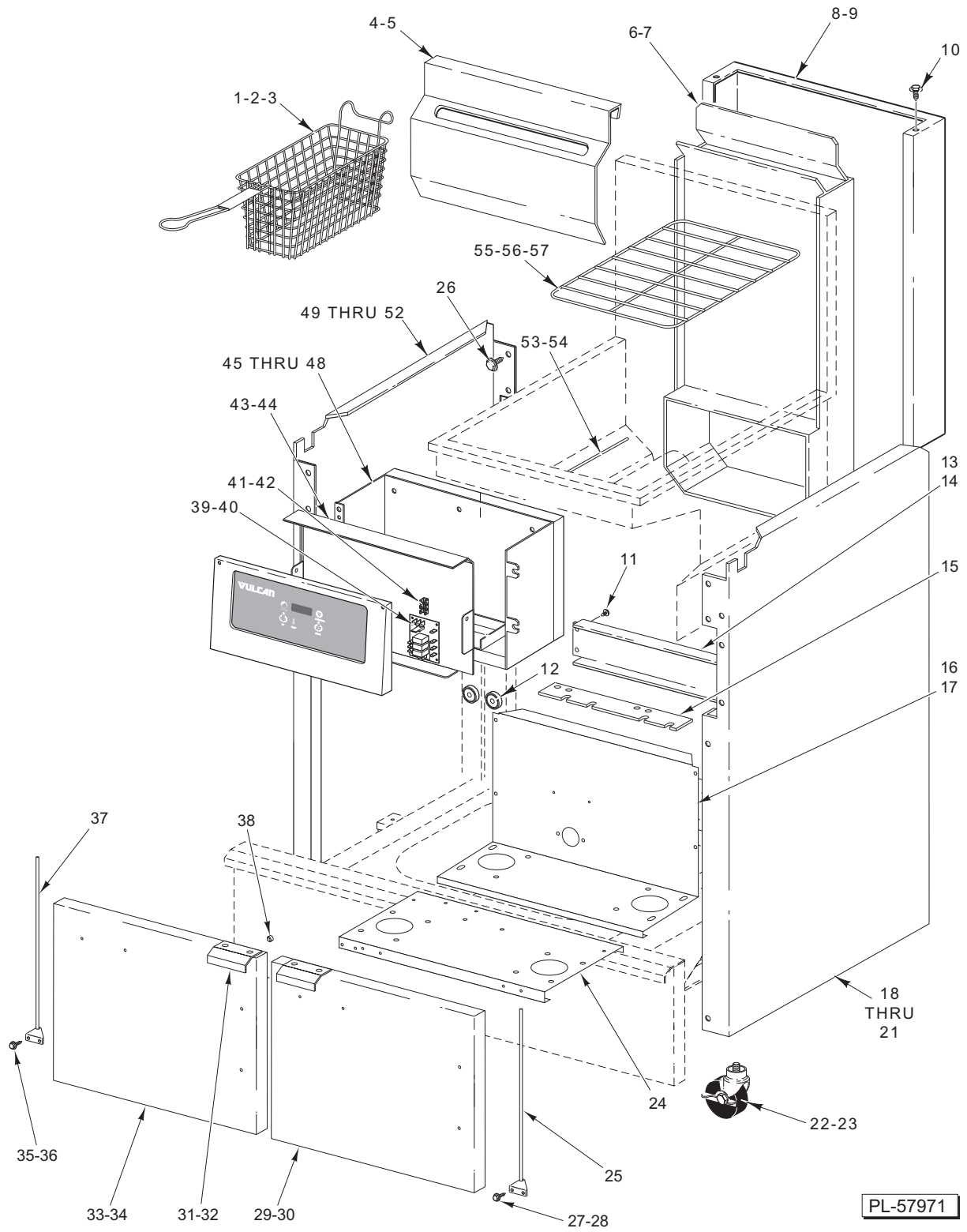

BODY UNIT (GRCF & GRDF SERIES)

BODY UNIT (GRCF & GRDF SERIES)

ILLUS.	PART NO.	NAME OF PART	AMT.
	PL-57971		
1	00-499223-00001	Basket – Twin (GR45DF & GR45CF)	AR
2	00-499223-00002	Basket – Twin (GR65DF & GR65CF)	AR
3	00-499223-00003	Basket – Twin (GR85DF & GR85CF)	AR
4	00-417056-00002	Hanger – Basket (GR45DF & GR45CF)	2
5	00-418321-00002	Hanger – Basket (GR65/85DF & GR65/85CF)	2
6	00-418201-000G2	Flue Assy. (4 Tube) (GR45CF/DF)	1
7	00-418205-000G5	Flue Assy. (5 Tube) (GR65CF/DF & GR85CF/DF)	1
8	00-416959-00002	Flue – Wrap (SST) (GR45DF & GR45CF)	2
9	00-418336-00002	Flue – Wrap (SST) (GR65/85DF & GR65/85CF)	2
10	SD-032-07	Self-Tapping Screw 10-24 x 1/2 Hex Washer Hd., Type TT	AR
11	SD-032-07	Self-Tapping Screw 10-24 x 1/2 Hex Washer Hd., Type TT	AR
12	00-497296-000G1	Magnet Assy.	2
13	00-428699-00002	Brace – Rear (GR45CF/DF)	1
14	00-428749-00002	Brace – Rear (GR65CF/DF & GR85CF/DF)	1
15	00-428688-00001	Bracket – Power Supply Mounting	1
16	00-497428-00001	Body – Bottom (3GR45CF/DF & 4GR45CF/DF)	1
17	00-497428-00003	Body – Bottom (3GR65CF/DF & 4GR65CF/DF)	1
18	00-419777-00004	Body – RH Side (SST) (GR85DF & GR85CF)	1
19	00-417711-00002	Body – RH Side (SST) (GR45/65DF & GR45/65CF)	1
20	00-419648-00002	Body – RH Side (SST) (GR45/65DF & GR45/65CF)	1
21	00-420596-00004	Body – RH Side (SST) (4GR85CF/DF)	1
22	00-418907-00001	Caster – Swivel Assy. (Adjustable)	2
23	00-418907-00003	Caster	2
24	00-497428-00004	Body – Bottom (3GR85CF/DF & 4GR85CF/DF)	1
25	00-428023-000G3	Hinge Assy. (RH Door) (4GR45CF/DF)	1
26	SD-036-03	Self-Tapping Screw 8-18 x 3/8 Hex Washer Hd., Type AB	AR
27	SD-032-07	Self-Tapping Screw 10-24 x 1/2 Hex Washer Hd., Type TT	1
28	NS-044-09	Nut Assy. 10-24 Hex KEPS	1
29	00-499487-000G4	Door Assy. (RH) (With Hinge) (GR45DF & GR45CF)	1
30	00-499487-000G8	Door Assy. (RH) (With Hinge) (GR65/85DF & GR65/85CF)	1
31	00-419653	Handle	2
32	RS-033-04	Rivet – Pop (0.187)	4
33	00-499487-000G3	Door Assy. (LH) (With Hinge) (GR45DF & GR45CF)	1
34	00-499487-000G7	Door Assy. (LH) (With Hinge) (GR65/85DF & GR65/85CF)	1
35	SD-032-07	Self-Tapping Screw 10-24 x 1/2 Hex Washer Hd., Type TT	2
36	NS-044-09	Nut Assy. 10-24 Hex KEPS	2
37	00-428023-000G2	Hinge Assy. (LH Door) (3GR45/65/85CF/DF & 4GR45/65/85CF/DF)	1
38	00-420769-00001	Bumper – Rubber (3GR45/65/85CF/DF & 4GR45/65/85CF/DF)	1
39	00-427759-00001	Control – Interface	1
40	SD-024-40	Self-Tapping Screw 6-32 x 5/8 Phil. Pan Hd., Type TT	4
41	00-419317	Terminal – Stationary	1
42	SC-060-23	Mach. Screw 4-40 x 1/4 Slotted Rd. Hd.	2
43	00-428541-00001	Plate – Control Mounting (GR45DF & GR45CF)	1
44	00-428690-00001	Plate – Control Mounting (GR65/85DF & GR65/85CF)	1
45	00-428542-00001	Heat Shield (GR45DF & GR45CF)	1
46	00-428689-00001	Heat Shield (GR65/85DF & GR65/85CF)	1
47	00-428548-00001	Heat Shield (4 Tube) (GR45CF/DF)	1
48	00-428548-00002	Heat Shield (5 Tube) (GR65CF/DF & GR85CF/DF)	1
49	00-419777-00003	Body – LH Side (SST) (GR85DF & GR85CF)	1
50	00-417711-00001	Body – LH Side (SST) (GR45/65DF & GR45/65CF)	1
51	00-419648-00001	Body – LH Side (SST) (GR45/65DF & GR45/65CF)	1
52	00-420596-00003	Body – LH Side (SST) (NFR) (GR85DF & GR85CF)	1
53	00-419379-00001	Probe – Thermistor	1
54	00-419592-00001	Clip – Thermistor Probe	1
55	00-427883-00002	Screen – Basket Support (GR45DF & GR45CF)	2
56	00-427883-00003	Screen – Basket Support (GR65DF & GR65CF)	2
57	00-427883-00004	Screen – Basket Support (GR85DF & GR85CF)	2
	00-421756-00001	Brush – Fryer Cleaning	1
	00-421490-000G1	Scoop	1
	00-410863-00002	Channel – Grease (GR45CF/DF & GR65CF/DF)	1
	00-410863-00006	Channel – Grease (GR85CF/DF)	1
	00-419967-00005	Cord – Power Supply (84 In.)	1

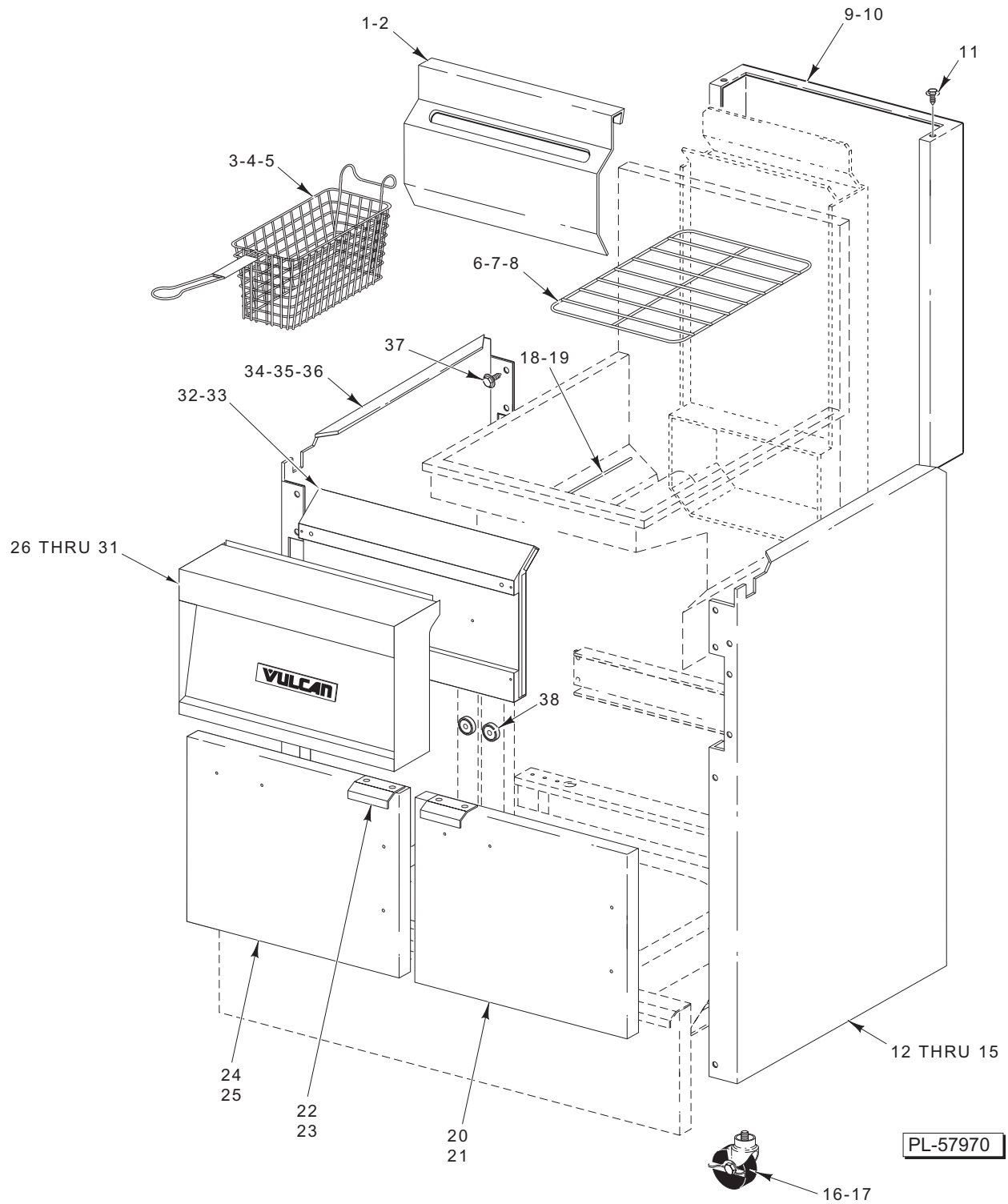

BODY UNIT (GRMF SERIES)

BODY UNIT (GRMF SERIES)

ILLUS. PL-57970	PART NO.	NAME OF PART	AMT.
1	00-417056-00002	Hanger – Basket (GR45MF).....	2
2	00-418321-00002	Hanger – Basket (GR65/85MF).....	2
3	00-499223-00001	Basket – Twin (Red Handle) (GR45MF).....	AR
4	00-499223-00002	Basket – Twin (Red Handle) (GR65MF).....	AR
5	00-499223-00003	Basket – Twin (Red Handle) (GR85MF).....	AR
6	00-427883-00002	Rack – Basket Support (GR45F).....	2
7	00-427883-00003	Rack – Basket Support (GR65F).....	2
8	00-427883-00004	Rack – Basket Support (GR85F).....	2
9	00-416959-00002	Flue – Wrap (SST) (GR45MF).....	2
10	00-418336-00002	Flue – Wrap (SST) (GR65/85MF).....	2
11	SD-032-07	Self-Tapping Screw 10-24 x 1/2 Hex Washer Hd., Type TT.....	AR
12	00-419777-00003	Body – LH Side (SST) (GR85MF).....	1
13	00-417711-00001	Body – LH Side (SST) (GR45/65MF).....	1
14	00-420596-00003	Body – LH Side (SST) (NFR) (GR85MF).....	1
15	00-419648-00001	Body – LH Side (SST) (GR45/65MF).....	1
16	00-418907-00001	Caster – Swivel Assy. (Adjustable).....	2
17	00-418907-00003	Caster.....	2
18	00-419379-00001	Probe – Thermistor.....	1
19	00-419592-00001	Clip – Thermistor Probe.....	1
20	00-499487-000G8	Door Assy. (RH) (GR65/85MF) (With Hinge).....	1
21	00-499487-000G4	Door Assy. (RH) (GR45MF) (With Hinge).....	1
22	00-419653	Handle.....	2
23	RS-033-09	Rivet – Pop (0.187).....	4
24	00-499487-000G7	Door Assy. (LH) (GR65/85MF) (With Hinge).....	1
25	00-499487-000G3	Door Assy. (LH) (GR45MF) (With Hinge).....	1
26	00-428116-000G3	Frame – Front Assy. (GR45MF) (2 Unit).....	1
27	00-428116-000G4	Frame – Front Assy. (GR65/85MF) (2 Unit).....	1
28	00-428116-000G5	Frame – Front Assy. (GR45MF) (3 Unit).....	1
29	00-428116-000G6	Frame – Front Assy. (GR65/85MF) (3 Unit).....	1
30	00-428116-000G7	Frame – Front Assy. (GR45MF) (4 Unit).....	1
31	00-417700-00002	Nameplate.....	1
32	00-418379-000G1	Heat Shield (GR45MF).....	1
33	00-418324-000G1	Heat Shield (GR65/85MF).....	1
34	00-419777-00004	Body – RH Side (SST) (GR85MF).....	1
35	00-417711-00002	Body – RH Side (SST) (GR45/65MF).....	1
36	00-419648-00002	Body – RH Side (SST) (GR45/65MF).....	1
37	SD-036-03	Self-Tapping Screw 8-18 x 3/8 Hex Washer Hd., Type AB.....	AR
38	00-497296-000G1	Magnet Assy.....	2

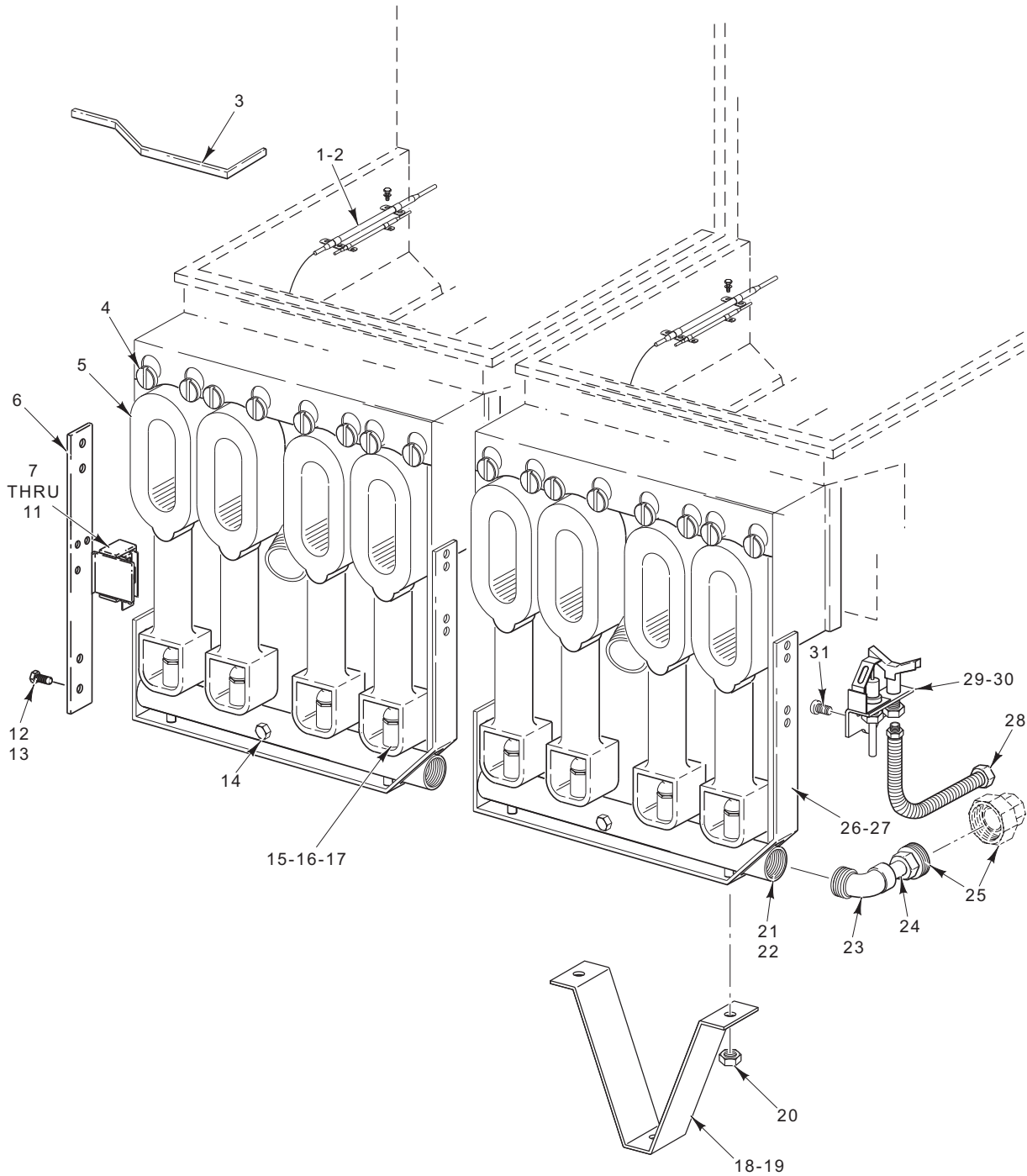

PL-57903

BURNER COMPONENTS (GRCF & GRDF SERIES)

BURNER COMPONENTS (GRCF & GRDF SERIES)

ILLUS. PL-57903	PART NO.	NAME OF PART	AMT.
1	00-417522-00003	Clip – Capillary.....	2
2	SD-035-02	Self-Tapping Screw 8-18 x 3/8 Hex Washer Hd., Type AB.....	4
3	00-409300-00005	Rod – Clean-Out.....	1
4	00-428035-00001	Bolt – Shoulder.....	AR
5	00-410681-00001	Burner.....	AR
6	00-417714-00001	Extension – Hanger.....	1
7	00-419548	Bracket – Hi-Limit.....	1
8	SD-037-70	Self-Tapping Screw 1/4-20 x 1/2 Hex Washer Hd., Type AB.....	4
9	NS-046-52	Nut – 1/4-20 Hex KEPS.....	4
10	SD-036-80	Self-Tapping Screw 8-32 x 3/8 Hex Washer Hd., Type TT.....	2
11	00-410840-00002	Box – Control Hi-Limit With Stuffing.....	1
12	SD-015-24	Self-Tapping Screw 1/4-20 x 1/2 Hex Washer Hd., Type TT.....	AR
13	NS-044-14	Nut – 1/4-20 Hex KEPS.....	AR
14	FP-085-53	Pipe Plug 1/8.....	1
15	00-010901-00039	Orifice – Spud (NAT Gas) (Sea Level – 2000 Ft.).....	AR
16	00-010901-00052	Orifice – Spud (LP Gas) (Sea Level – 3499 Ft.).....	AR
17	00-410695-00001	Extension – Orifice.....	AR
18	00-420561-00001	Bracket – Support (3GR45CF/DF).....	1
19	00-420562-00001	Bracket – Support (4GR65CF/DF & 4GR85CF/DF).....	1
20	NS-047-72	Lock Nut 1/4-20.....	2
21	00-418212-00001	Manifold – Burner (4 Tube).....	1
22	00-418318-00001	Manifold – Burner (5 Tube).....	1
23	FP-086-74	Elbow – Pipe 1/2 x 90 Deg.....	1
24	FP-035-94	Pipe 1/2 x 1 1/2 Lg. TBE.....	1
25	FP-022-11	Union – Pipe.....	AR
26	00-418211-00001	Hanger – Manifold (4 Tube).....	1
27	00-418317-00001	Hanger – Manifold (5 Tube).....	1
28	00-426505-00023	Tube – Flex 1/4 O.D. x 23 In. Lg.....	1
29	00-419316-00001	Pilot (NAT Gas) (With Electronic Ignition).....	1
30	00-419316-00002	Pilot (LP Gas) (With Electronic Ignition).....	1
31	SC-018-32	Mach. Screw 8-32 x 3/8 Pan Hd.....	2
	00-427953-00001	Bracket – Tank To Pilot.....	1
	00-427952-00001	Bracket – Pilot Mounting.....	1
	00-419359	Cable – Ignitor Wire (36 In.).....	1

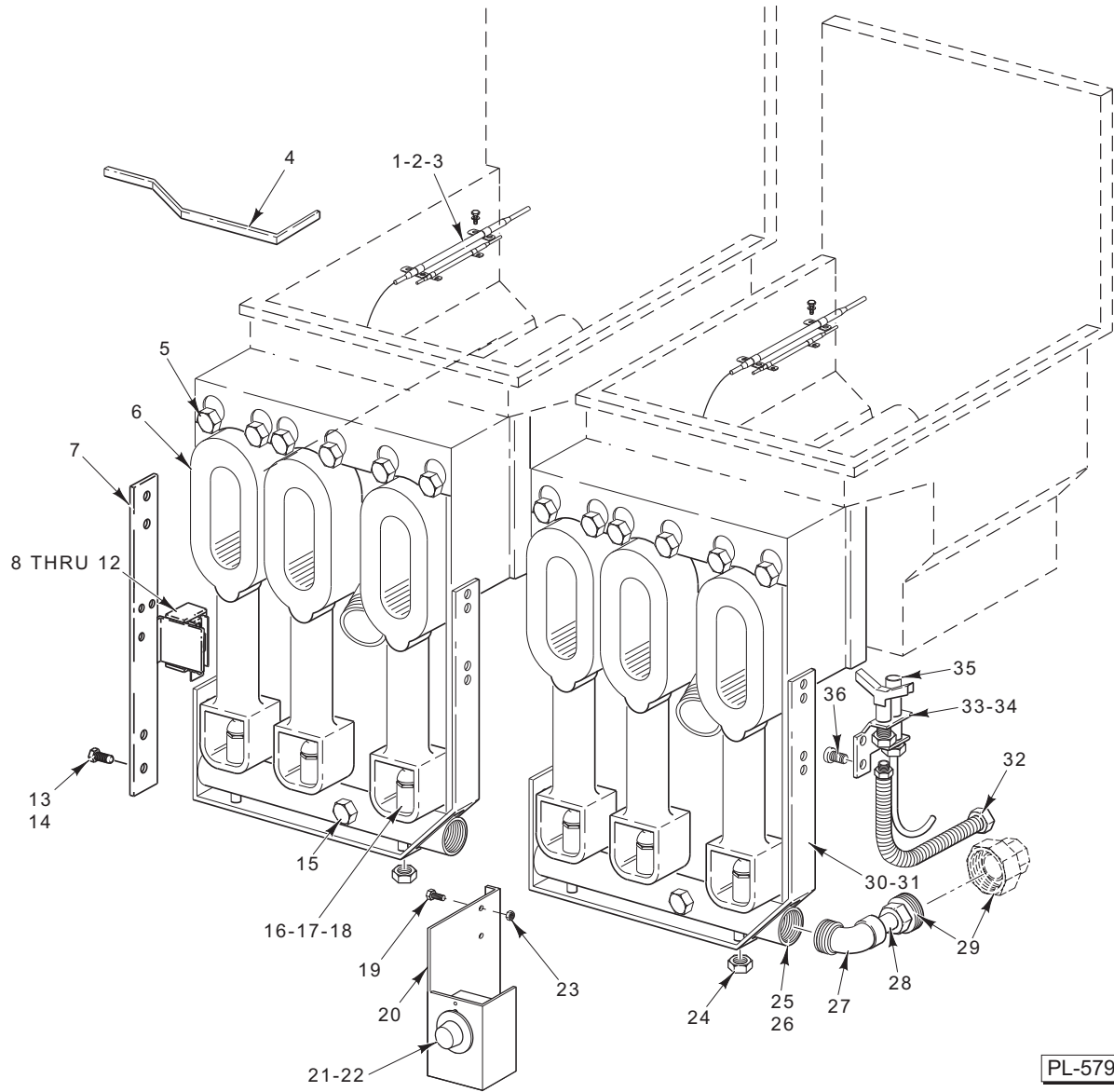

BURNER COMPONENTS (GRMF SERIES)

BURNER COMPONENTS (GRMF SERIES)

ILLUS. PL-57904	PART NO.	NAME OF PART	AMT.
1	00-402558-00005	Clamp	2
2	00-417522-00003	Clip – Speed Nut.....	2
3	SD-035-02	Self-Tapping Screw 8-18 x ³ / ₈ Hex Washer Hd., Type AB.....	4
4	00-409300-00005	Rod – Clean-Out.....	1
5	SC-062-07	Cap Screw ⁵ / ₁₆ -18 x ¹ / ₂ Hex Hd.	AR
6	00-410681-00001	Burner	AR
7	00-417714-00001	Extension – Hanger	1
8	00-419548	Bracket – Hi-Limit	1
9	SD-037-70	Self-Tapping Screw ¹ / ₄ -20 x ¹ / ₂ Hex Washer Hd., Type AB.....	4
10	NS-046-52	Nut – ¹ / ₄ -20 Hex KEPS.....	4
11	SD-036-80	Self-Tapping Screw 8-32 x ³ / ₈ Hex Washer Hd., Type TT	2
12	00-410840-00002	Box – Control Hi-Limit With Stuffing	1
13	SD-015-24	Self-Tapping Screw ¹ / ₄ -20 x ¹ / ₂ Hex Washer Hd., Type TT.....	AR
14	NS-044-14	Nut – ¹ / ₄ -20 Hex KEPS.....	AR
15	FP-085-53	Pipe Plug ¹ / ₈	1
16	00-010901-00039	Orifice – Spud (NAT Gas) (Sea Level – 2000 Ft.).....	AR
17	00-010901-00052	Orifice – Spud (LP Gas) (Sea Level – 3499 Ft.).....	AR
18	00-410695-00001	Extension – Orifice.....	AR
19	SD-037-70	Self-Tapping Screw ¹ / ₄ -20 x ¹ / ₂ Hex Washer Hd., Type TT.....	2
20	00-497089-00001	Bracket – Control	1
21	00-408659-00005	Knob – Thermostat	1
22	00-411506-00013	Thermostat – Reed.....	1
23	NS-046-52	Nut ¹ / ₄ -20 Hex	6
24	NS-047-72	Lock Nut ¹ / ₄ -20	2
25	00-418212-00001	Manifold – Burner (GR45MF)	1
26	00-418318-00001	Manifold – Burner (GR65/85MF)	1
27	FP-086-74	Elbow – Pipe ¹ / ₂ x 90 Deg.	1
28	FP-035-94	Pipe ¹ / ₂ x 1 ¹ / ₂ Lg. TBE.....	1
29	FP-022-11	Union – Pipe	AR
30	00-418211-00001	Hanger – Manifold (GR45MF)	1
31	00-418317-00001	Hanger – Manifold (GR65/85MF)	1
32	00-426505-00023	Tube – Flex ¹ / ₄ O.D. x 23 In. Lg.	1
33	00-412212-00007	Pilot (NAT Gas).....	1
34	00-412212-00002	Pilot (LP Gas).....	1
35	00-410839-00004	Thermopile (500 MV).....	2
36	SC-018-32	Mach. Screw 8-32 x ³ / ₈ Pan Hd.....	2

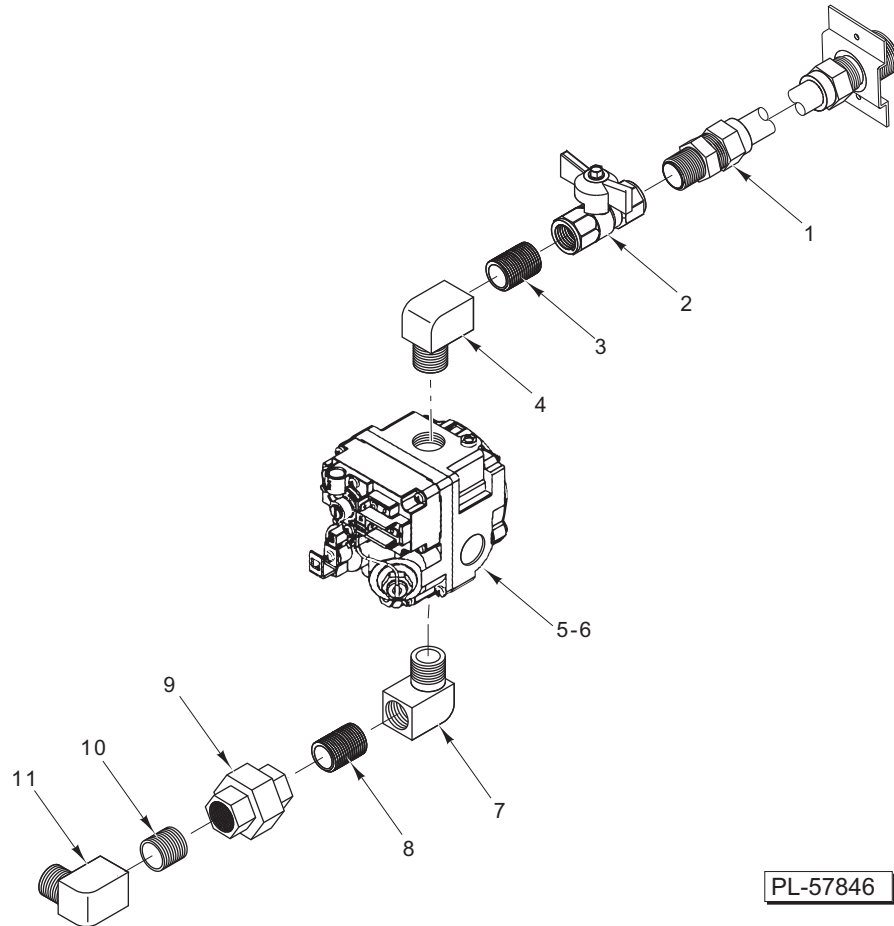

PL-57846

GAS VALVE (GRCF & GRDF SERIES) (PREVIOUS CONSTRUCTION)

ILLUS.	PART NO.	NAME OF PART	AMT.
	PL-57846		
1	00-427882-000G3	Gas Inlet (GR45/65/85CF & GR45/65/85DF)	1
2	00-428472-00001	Valve – Ball	1
3	FP-035-91	Pipe 1/2 x 1 1/8 TBE.....	1
4	FP-086-74	Elbow – Street 1/2 x 90 Deg. (Brass)	1
*5	00-410841-00028	Valve – Combination (NAT) (Electronic Ignition).....	1
*6	00-410841-00029	Valve – Combination (LP) (Electronic Ignition)	1
7	FP-086-74	Elbow – Street 1/2 x 90 Deg. (Brass)	1
8	FP-035-91	Pipe 1/2 x 1 1/8 TBE.....	1
9	FP-022-11	Union – Pipe	1
10	FP-035-94	Pipe 1/2 x 1 1/2 TBE.....	1
11	FP-086-74	Elbow – Street 1/2 x 90 Deg. (Brass)	1
	00-427751-000G1	Harness – Section	1

* Order part number 00-427751-000G1 when replacing valve.

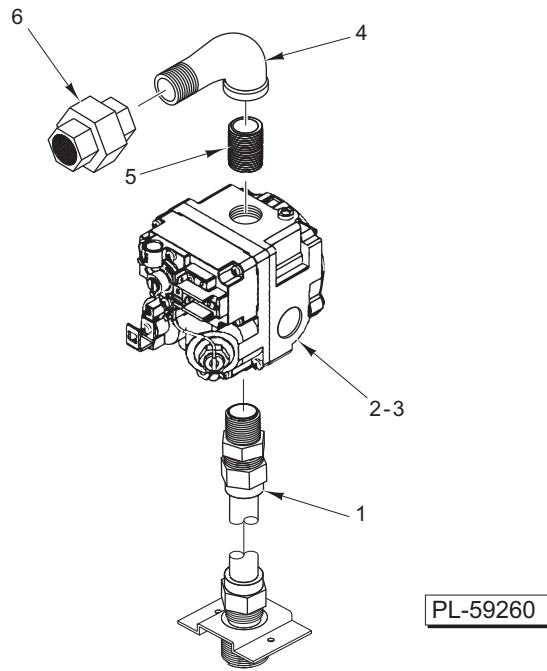

GAS VALVE (GRCF & GRDF SERIES) (CURRENT CONSTRUCTION)

ILLUS.	PART NO.	NAME OF PART	AMT.
PL-59260			
1	00-427882-000G3	Gas Inlet	1
2	00-410841-00028	Valve – Combination (NAT) (Electronic Ignition).....	1
3	00-410841-00029	Valve – Combination (LP) (Electronic Ignition)	1
4	FP-013-17	Elbow – Pipe 1/2 x 90 Deg.	1
5	FP-035-95	Pipe 1/2 x 2 TBE.....	1
6	FP-022-11	Union – Pipe	1

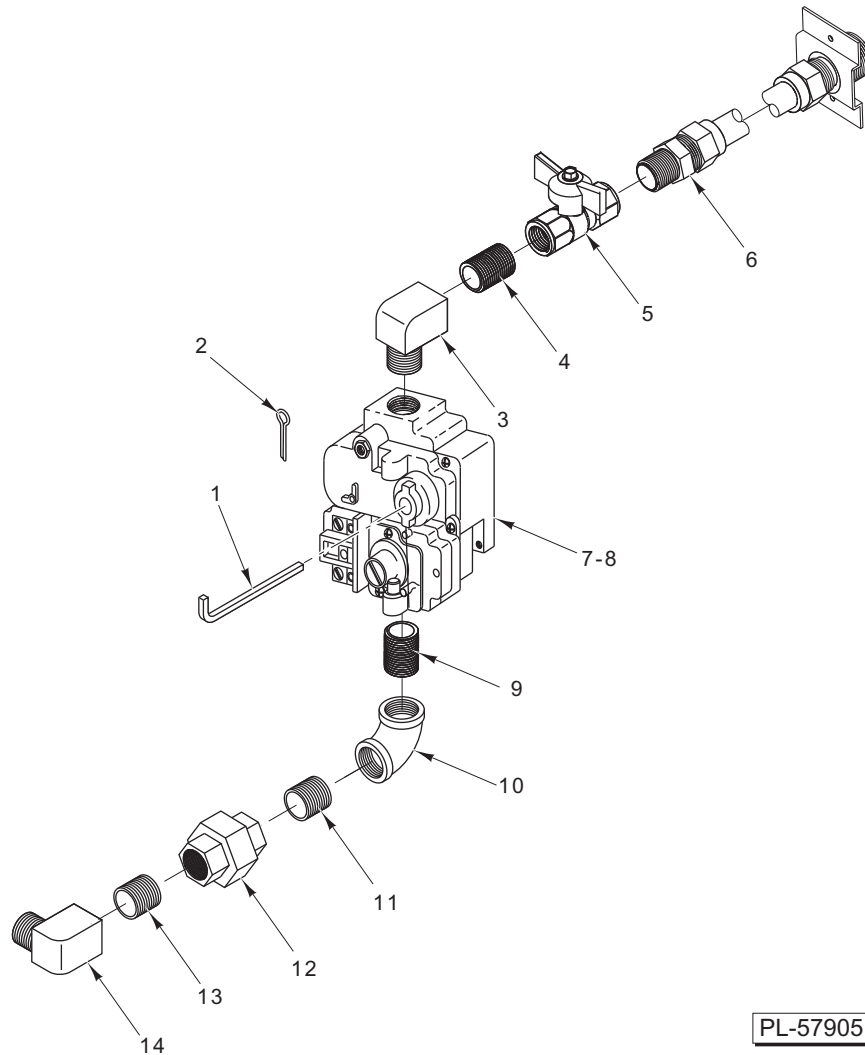

**GAS VALVE (GRMF SERIES)
(PREVIOUS CONSTRUCTION)**

ILLUS.	PART NO.	NAME OF PART	AMT.
PL-57905			
1	00-413433-00007	Lever – Pilot Actuating.....	1
2	PC-003-38	Pin – Cotter.....	1
3	FP-086-74	Elbow – Street 1/2 x 90 Deg. (Brass).....	1
4	FP-035-91	Pipe 1/2 x 1/8 TBE.....	1
5	00-428472-00001	Valve – Ball.....	1
6	00-427882-000G3	Gas Inlet (GR45/65/85MF).....	1
7	00-497616-000G1	Kit – Combination Valve (NAT) (Manual Ignition).....	1
8	00-497616-000G2	Kit – Combination Valve (LP) (Manual Ignition).....	1
9	FP-036-94	Pipe 1/2 x 2 1/2 TBE.....	1
10	FP-077-68	Elbow – Pipe 1/2 x 90 Deg.	1
11	FP-035-91	Pipe 1/2 x 1/8 TBE.....	1
12	FP-022-11	Union – Pipe.....	1
13	FP-035-91	Pipe 1/2 x 1/8 TBE.....	1
14	FP-086-74	Elbow – Street 1/2 x 90 Deg. (Brass).....	1

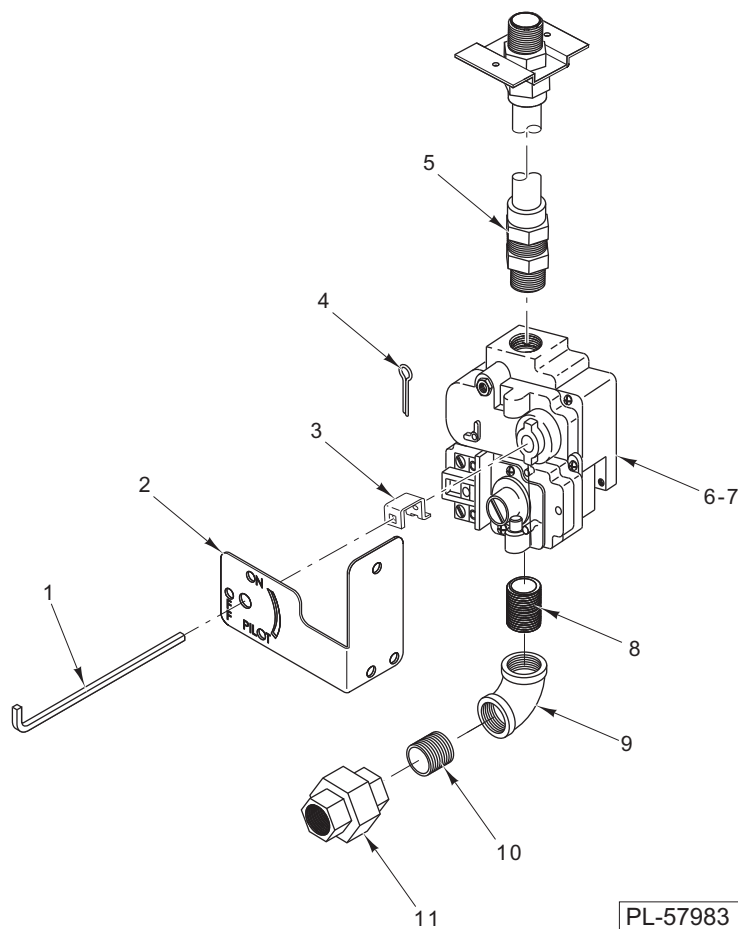

**GAS VALVE (GRMF SERIES)
(CURRENT CONSTRUCTION)**

ILLUS.	PART NO.	NAME OF PART	AMT.
PL-57983			
1	00-413433-00006	Lever – Valve	1
2	00-428755-00002	Bracket – Pilot Lever.....	1
3	00-412080-00001	Adapter – Knob.....	1
4	PC-003-38	Pin – Cotter.....	1
5	00-427882-000G3	Gas Inlet (GR45/65/85MF)	1
6	00-410841-00022	Valve – Combination (NAT) (Manual Ignition).....	1
7	00-410841-00023	Valve – Combination (LP) (Manual Ignition)	1
8	FP-035-95	Pipe 1/2 x 2 TBE.....	1
9	FP-013-17	Pipe 1/2 x 90 Deg.....	1
10	FP-035-95	Pipe 1/2 x 2 TBE.....	1
11	FP-022-11	Union – Pipe	1

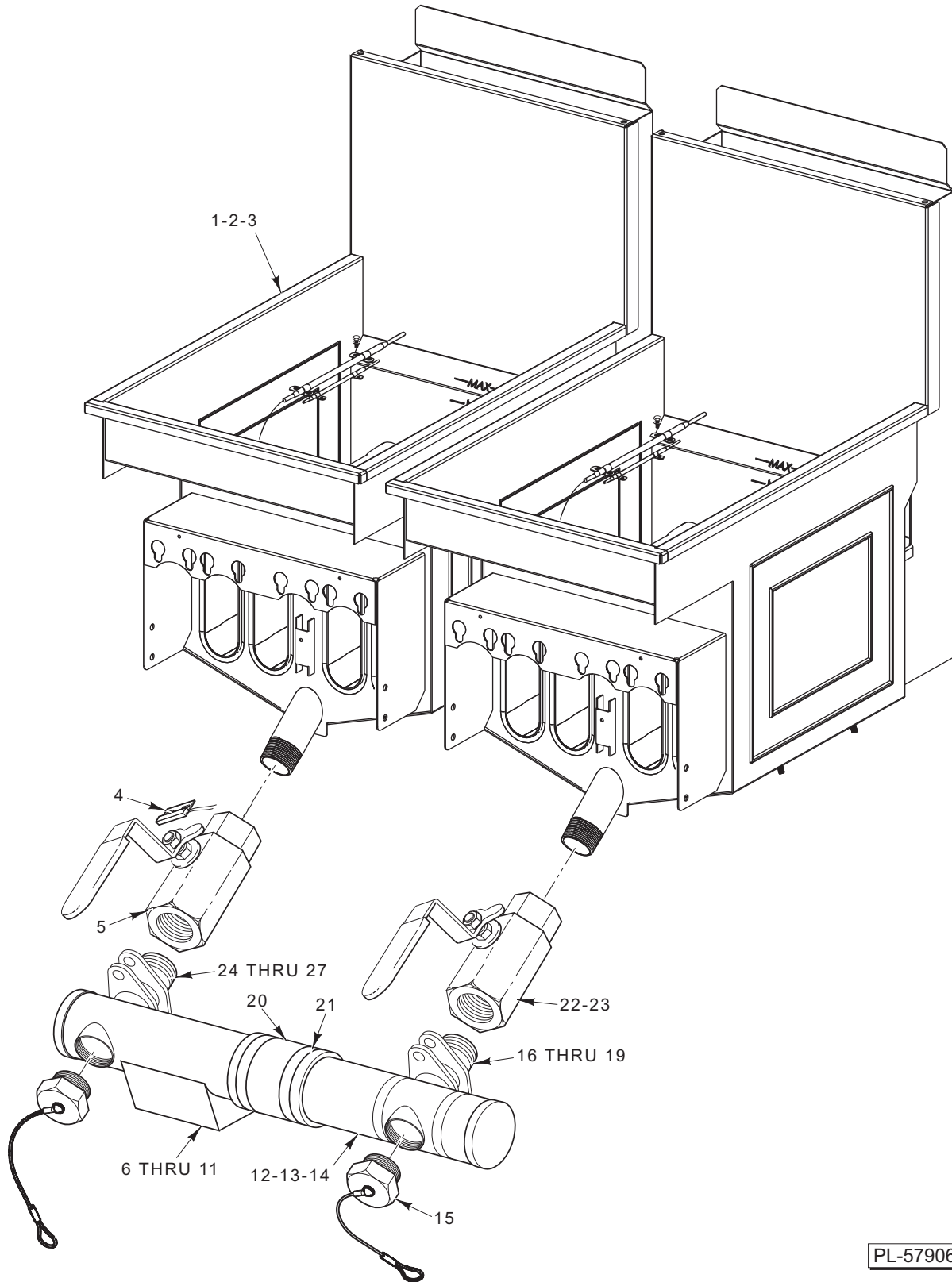

TANK AND DRAIN

TANK AND DRAIN

ILLUS. PL-57906	PART NO.	NAME OF PART	AMT.
1	00-499701-000G2	Tank Assy. (SST) (GR45 Series).....	1
2	00-499702-000G2	Tank Assy. (SST) (GR65 Series).....	1
3	00-499703-000G2	Tank Assy. (GR85 Series).....	1
4	00-426805-000G1	Switch Assy. (Drain Valve Interlock) (GRCF & GRDF Series).....	1
5	00-958392-000G1	Valve Assy. – Drain (LH) (GRMF Series).....	1
6	00-497567-000G1	Pipe – Drain (LH) With Spout (2GR45).....	1
7	00-497567-000G2	Pipe – Drain (LH) With Spout (2GR65 & 2GR85).....	1
8	00-497569-000G1	Pipe – Drain (Center) With Spout (3GR45 & 4GR45).....	1
9	00-497569-000G2	Pipe – Drain With Spout (GR65 & GR85).....	1
10	00-497568-000G1	Pipe – Drain (Center) (4GR45).....	1
11	00-497568-000G2	Pipe – Drain (Center) (4GR65 & 4GR85).....	1
12	00-497566-000G1	Pipe – Drain (End) (45 Lbs.) (2GR45, 3GR45, & 4GR45).....	1
13	00-497566-000G3	Pipe – Drain (RH) (65/85 Lbs.) (2GR65, 2GR85, 3GR65, 3GR85, 4GR65, & 4GR85).....	1
14	00-497566-000G2	Pipe – End Section (LH) (5 Tube) (3GR65, 3GR85, 4GR65, & 4GR85).....	1
15	00-497571-000G1	Plug – Drain.....	2
16	00-420726-00001	Flange – Pipe (1 ¹ / ₄ In.).....	1
17	00-420553-00002	Gasket – Silicone.....	1
18	FP-090-69	Pipe 1 ¹ / ₄ x 1 TBE.....	1
19	SC-036-13	Cap Screw 1 ¹ / ₄ -20 x 3 ³ / ₄ Hex Hd.....	2
20	00-419351-00001	Hose – Connect.....	AR
21	00-497409-00001	Clamp – Drain Tube.....	AR
22	00-426803-000G9	Valve – RH Drain Assy. (1 ¹ / ₄ In.) (With Magnet).....	1
23	00-958392-000G2	Valve Assy. – Drain (RH) (1 ¹ / ₄ In.) (GRMF Series).....	1
24	00-420553-00002	Gasket – Silicone.....	1
25	00-420726-00001	Flange – Pipe (1 ¹ / ₄ In.).....	1
26	FP-090-69	Pipe 1 ¹ / ₄ x 1 TBE.....	1
27	SC-036-13	Cap Screw 1 ¹ / ₄ -20 x 3 ³ / ₄ Hex Hd.....	2
	00-499486-00001	Clip – Drain Pipe.....	1
	00-497572-000G2	Pipe – Boil Out Bypass (With Hose Fitting).....	1

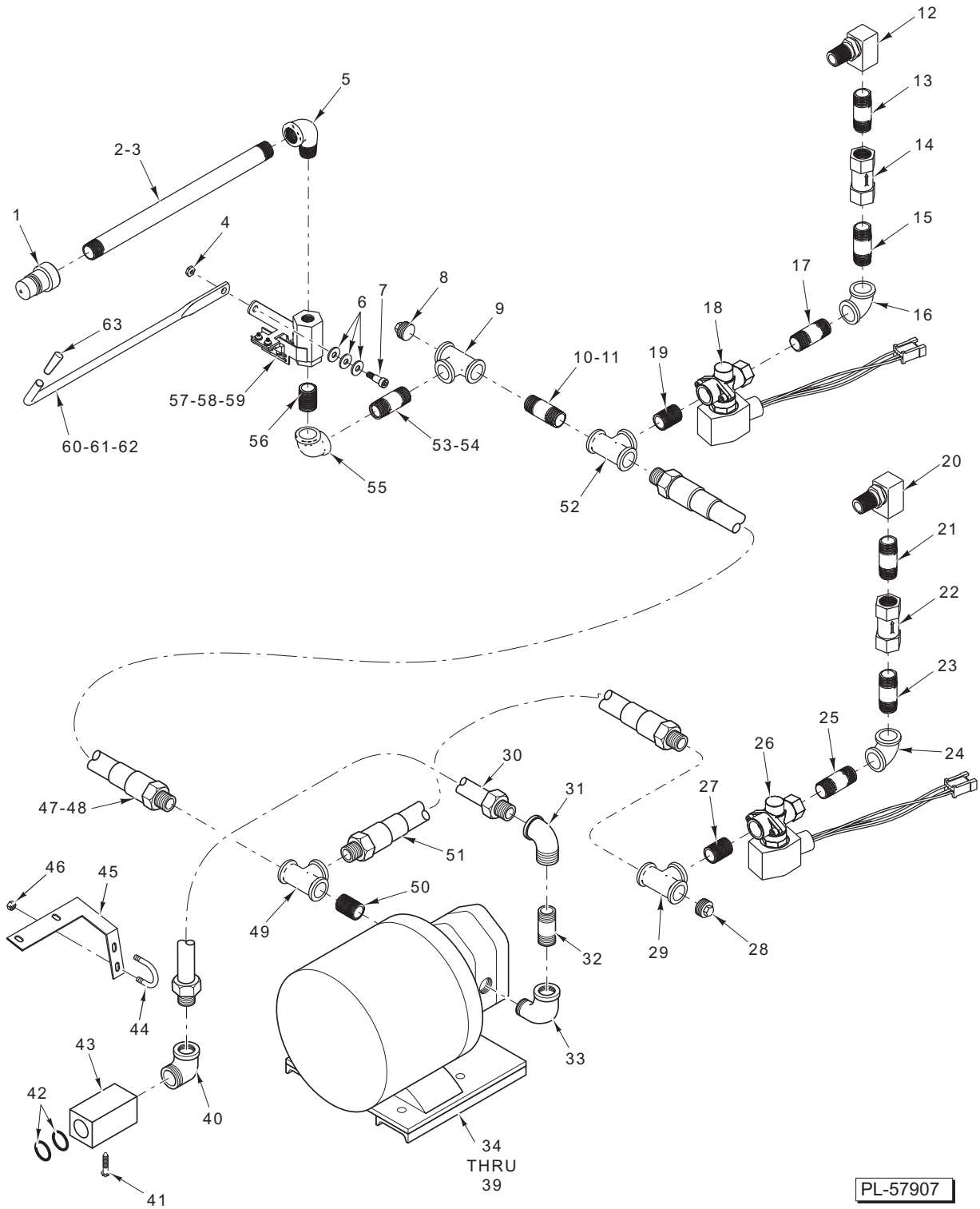

OIL RETURN (GRCF AND GRDF SERIES)

OIL RETURN (GRCF AND GRDF SERIES)

ILLUS. PL-57907	PART NO.	NAME OF PART	AMT.
1	00-418781-00001	Quick Disconnect.....	1
2	FP-080-44	Pipe 1/2 x 12 TBE (GR45/65CF & GR45/65DF)	1
3	FP-080-92	Pipe 1/2 x 16 TBE (GR85CF & GR85DF)	1
4	NS-046-52	Nut Assy. 1/4-20 Hex KEPS	1
5	FP-013-17	Elbow – Street 1/2 x 90 Deg.	1
6	WS-005-06	Washer.....	3
7	SC-113-34	Shoulder Screw 1/4-20 x 1/2 Hex Socket Hd.	1
8	FP-028-14	Pipe – Plug 1/2 Sq. Hd.	1
9	FP-019-25	Tee 1/2 x 1/2 x 1/2	1
10	FP-035-95	Pipe 1/2 x 2 TBE (GR45CF & GR45DF)	1
11	FP-059-85	Pipe 1/2 x 4 3/4 TBE (GR65/85CF & GR65/85DF)	1
12	00-419251-00001	Elbow – Swivel 1/2 NPTF	1
13	FP-035-95	Pipe 1/2 x 2 TBE.....	1
14	00-418786-00001	Check Valve.....	1
15	FP-035-95	Pipe 1/2 x 2 TBE.....	1
16	FP-077-68	Elbow – Pipe 1/2 x 90 Deg.	1
17	FP-035-95	Pipe 1/2 x 2 TBE.....	1
18	00-428691-00002	Valve – Solenoid.....	1
19	FP-035-91	Pipe 1/2 x 1 1/8 TBE.....	1
20	00-419251-00001	Elbow - Swivel 1/2 NPTF	1
21	FP-035-95	Pipe 1/2 x 2 TBE.....	1
22	00-418786-00001	Check Valve.....	1
23	FP-035-95	Pipe 1/2 x 2 TBE.....	1
24	FP-077-68	Elbow – Pipe 1/2 x 90 Deg.	1
25	FP-035-95	Pipe 1/2 x 2 TBE.....	1
26	00-428691-00002	Valve – Solenoid.....	1
27	FP-035-91	Pipe 1/2 x 1 1/8 TBE.....	1
28	FP-028-14	Pipe – Plug 1/2 Sq. Hd.	1
29	FP-019-25	Tee 1/2 x 1/2 x 1/2	1
30	00-426602-00002	Tube – Flex (29 In.).....	1
31	FP-077-68	Elbow – Pipe 1/2 x 90 Deg.	1
32	FP-035-94	Pipe 1/2 x 1 1/2 TBE.....	1
33	FP-077-68	Elbow – Pipe 1/2 x 90 Deg.	1
34	00-417792-00001	Pump Motor Assy. (120 V., 60 Hz.) (5.6 G.P.M.) (Previous Construction)	1
35	00-417792-00003	Pump Motor Assy. (208 V., 50/60 Hz.) (5.6 G.P.M.) (Previous Construction)	1
36	00-417792-00004	Pump Motor Assy. (230 V., 50/60 Hz.) (5.6 G.P.M.) (Previous Construction)	1
37	00-417792-00005	Pump Motor Assy. (115 V., 60 Hz.) (8 G.P.M.) (Current Construction).....	1
38	00-417792-00006	Pump Motor Assy. (208 V., 50/60 Hz.) (8 G.P.M.) (Current Construction)	1
39	00-417792-00007	Pump Motor Assy. (230 V., 50/60 Hz.) (8 G.P.M.) (Current Construction)	1
40	FP-013-17	Elbow – Street 1/2 x 90 Deg.	1
41	SC-114-01	Mach. Screw 10-32 x 3/8 Hex Washer Hd.	1
42	00-426567-00002	O-Ring (Viton).....	2
43	00-426567-00003	Receptacle – Oil Suction	1
44	00-521820	U-Bolt.....	1
45	00-497087-00001	Bracket – Quick Disconnect.....	1
46	NS-046-52	Nut Assy. 1/4-20 Hex KEPS	1
47	00-426602-00001	Tube – Flex (12 In.).....	1
48	00-426602-00004	Tube – Flex (19 In.).....	1
49	FP-019-25	Tee 1/2 x 1/2 x 1/2	1
50	FP-035-91	Pipe 1/2 x 1 1/8 TBE.....	1
51	00-426602-00004	Tube – Flex (19 In.).....	1
52	FP-019-25	Tee 1/2 x 1/2 x 1/2	1
53	FP-035-94	Pipe 1/2 x 1 1/2 TBE (GR45/65CF & GR45/65DF)	1
54	FP-035-95	Pipe 1/2 x 2 TBE (GR85CF & GR85DF)	1
55	FP-077-68	Elbow – Pipe 1/2 x 90 Deg.	1
56	FP-035-95	Pipe 1/2 x 2 TBE (GR45/65/85CF & GR45/65/85DF)	1
57	00-428694-000G1	Valve Assy.....	1
58	00-426801-00002	Switch – Magnetic.....	1
59	00-426805-000G2	Switch – Magnetic (Wired).....	1
60	00-428693-00001	Rod – Pull (GR45/65CF & GR45/65DF) (Previous Construction)	1
61	00-428693-00002	Rod – Pull (GR85CF & GR85DF) (Previous Construction)	1
62	00-428693-00004	Rod – Pull Kleenscreen (Current Construction).....	1
63	00-416435-00002	Grip (Yellow)	1
	00-422281-00007	Hose – Discard (6 Ft.).....	1
	00-428715-00001	Bracket – Pull Rod.....	1

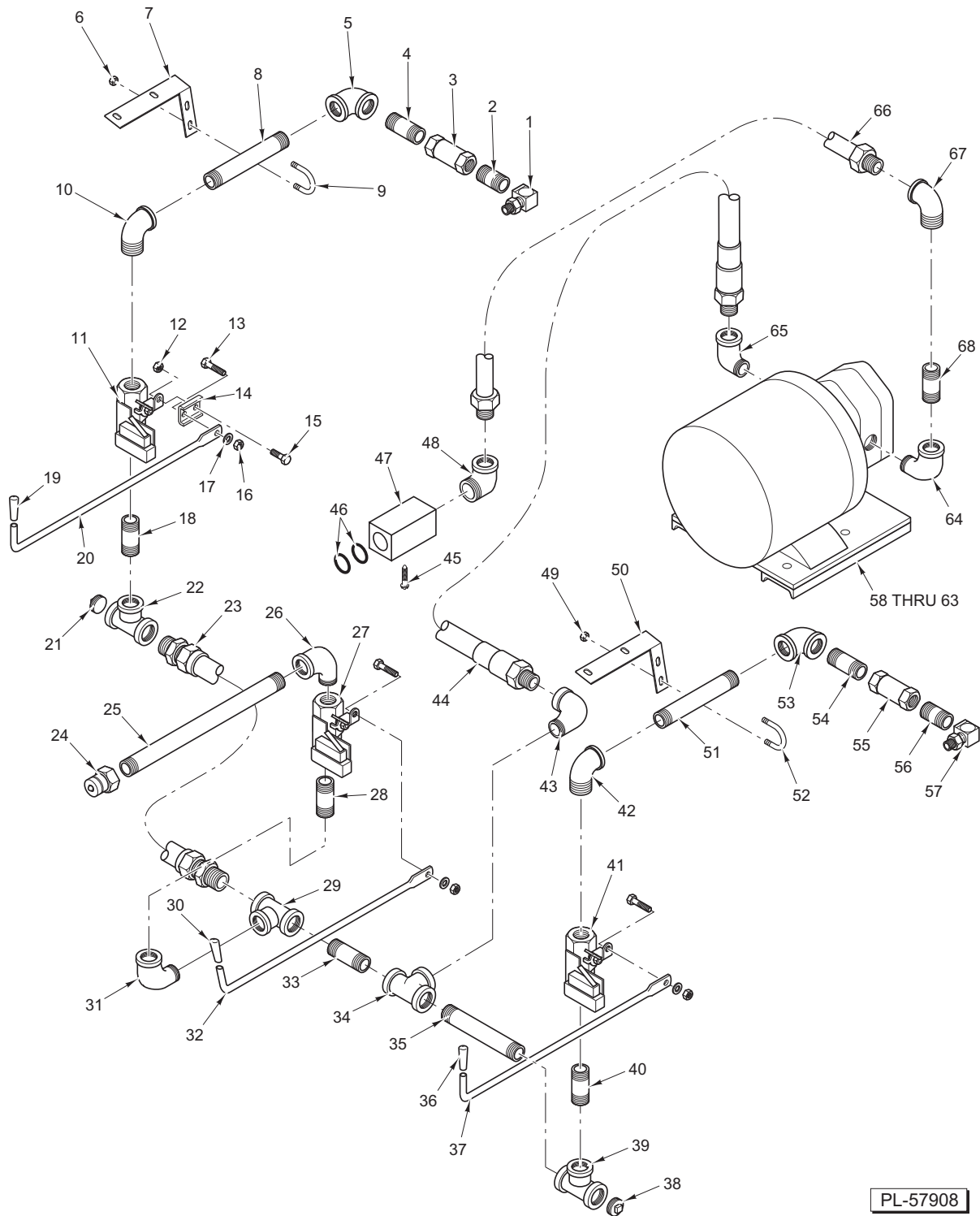

PL-57908

OIL RETURN (GR45MF)

ILLUS.	PART NO.	NAME OF PART	AMT.
PL-57908			
1	00-419251-00001	Fitting – 90 Deg. Swivel	1
2	FP-035-91	Pipe 1/2 x 1 1/8 TBE.....	1
3	00-418786-00001	Valve – Check.....	1
4	FP-035-94	Pipe 1/2 x 1 1/2 TBE.....	1
5	FP-077-68	Elbow 1/2 x 90 Deg.	1

OIL RETURN (GR45MF) (CONT.)

ILLUS. PL-57908	PART NO.	NAME OF PART	AMT.
6	NS-046-52	Nut Assy. 1/4-20 Hex.....	2
7	00-428955-00001	Bracket – Oil Return (Previous Construction).....	1
8	FP-058-49	Pipe 1/2 x 3 1/2 TBE.....	1
9	00-521820	U-Bolt.....	1
10	FP-013-17	Elbow – Street 1/2 x 90 Deg.....	1
11	00-419291-000G1	Valve Assy.....	1
12	NS-044-14	Nut Assy. 1/4-20 Hex KEPS.....	1
13	SC-113-34	Shoulder Screw 1/4-20 x 1/2 Hex Socket Hd.....	3
14	00-428956-00001	Extension – Pull Rod (Previous Construction).....	1
15	SC-110-12	Cap Screw 1/4-20 x 5/8 Hex Hd.....	1
16	NS-044-14	Nut Assy. 1/4-20 Hex KEPS.....	3
17	WS-005-06	Washer.....	9
18	FP-035-94	Pipe 1/2 x 1 1/2 TBE.....	1
19	00-416435-00001	Grip (Red).....	1
20	00-428693-00004	Rod – Pull Kleenscreen.....	1
21	FP-028-14	Pipe – Plug 1/2 Sq. Hd.....	1
22	FP-019-25	Tee 1/2 x 1/2 x 1/2.....	1
23	00-426602-00001	Tube – Flex (12 In.).....	1
24	00-418781-00001	Quick Disconnect.....	1
25	FP-080-43	Pipe 1/2 x 15.....	1
26	FP-013-17	Elbow – Street 1/2 x 90 Deg.....	1
27	00-419291-000G1	Valve Assy.....	1
28	FP-035-94	Pipe 1/2 x 1 1/2 TBE.....	1
29	FP-019-25	Tee 1/2 x 1/2 x 1/2.....	1
30	00-416435-00002	Grip (White).....	1
31	FP-013-17	Elbow – Street 1/2 x 90 Deg.....	1
32	00-428693-00001	Rod – Discard.....	1
33	FP-035-94	Pipe 1/2 x 1 1/2 TBE.....	1
34	FP-019-25	Tee 1/2 x 1/2 x 1/2.....	1
35	FP-035-95	Pipe 1/2 x 2 TBE.....	1
36	00-416435-00001	Grip (Red).....	1
37	00-428693-00004	Rod – Pull Kleenscreen.....	1
38	FP-028-14	Pipe – Plug 1/2 Sq. Hd.....	1
39	FP-019-25	Tee 1/2 x 1/2 x 1/2.....	1
40	FP-035-94	Pipe 1/2 x 1 1/2 TBE.....	1
41	00-419291-000G1	Valve Assy.....	1
42	FP-013-17	Elbow – Street 1/2 x 90 Deg.....	1
43	FP-013-17	Elbow – Street 1/2 x 90 Deg.....	1
44	00-426602-00001	Tube Flex (12 In.).....	1
45	SC-114-01	Mach. Screw 10-32 x 3/8 Hex Washer Hd.....	1
46	00-426567-00002	O-Ring (Viton).....	2
47	00-426567-00003	Receptacle – Oil Suction.....	1
48	FP-013-17	Elbow – Street 1/2 x 90 Deg.....	1
49	NS-046-52	Nut Assy. 1/4-20 Hex.....	2
50	00-428955-00001	Bracket – Oil Return (Previous Construction).....	1
51	FP-058-49	Pipe 1/2 x 3 1/2.....	1
52	00-521820	U-Bolt.....	1
53	FP-077-68	Elbow 1/2 x 90 Deg.....	1
54	FP-035-94	Pipe 1/2 x 1 1/2 TBE.....	1
55	00-418786-00001	Valve – Check.....	1
56	FP-035-91	Pipe 1/2 x 1 1/8 TBE.....	1
57	00-419251-00001	Fitting – 90 Deg. Swivel.....	1
58	00-417792-00001	Pump Motor Assy. (120 V., 60 Hz.) (5.6 G.P.M.) (Previous Construction).....	1
59	00-417792-00003	Pump Motor Assy. (208 V., 50/60 Hz.) (5.6 G.P.M.) (Previous Construction).....	1
60	00-417792-00004	Pump Motor Assy. (230 V., 50/60 Hz.) (5.6 G.P.M.) (Previous Construction).....	1
61	00-417792-00005	Pump Motor Assy. (115 V., 60 Hz.) (8 G.P.M.) (Current Construction).....	1
62	00-417792-00006	Pump Motor Assy. (208 V., 50/60 Hz.) (8 G.P.M.) (Current Construction).....	1
63	00-417792-00007	Pump Motor Assy. (230 V., 50/60 Hz.) (8 G.P.M.) (Current Construction).....	1
64	FP-077-68	Elbow 1/2 x 90 Deg.....	1
65	FP-013-17	Elbow – Street 1/2 x 90 Deg.....	1
66	00-426602-00002	Tube – Flex (29 In.).....	1
67	FP-077-68	Elbow 1/2 x 90 Deg.....	1
68	FP-035-94	Pipe 1/2 x 1 1/2 TBE.....	1
	00-411496-000F7	Micro Switch (Included With Items 11, 27, & 41).....	1

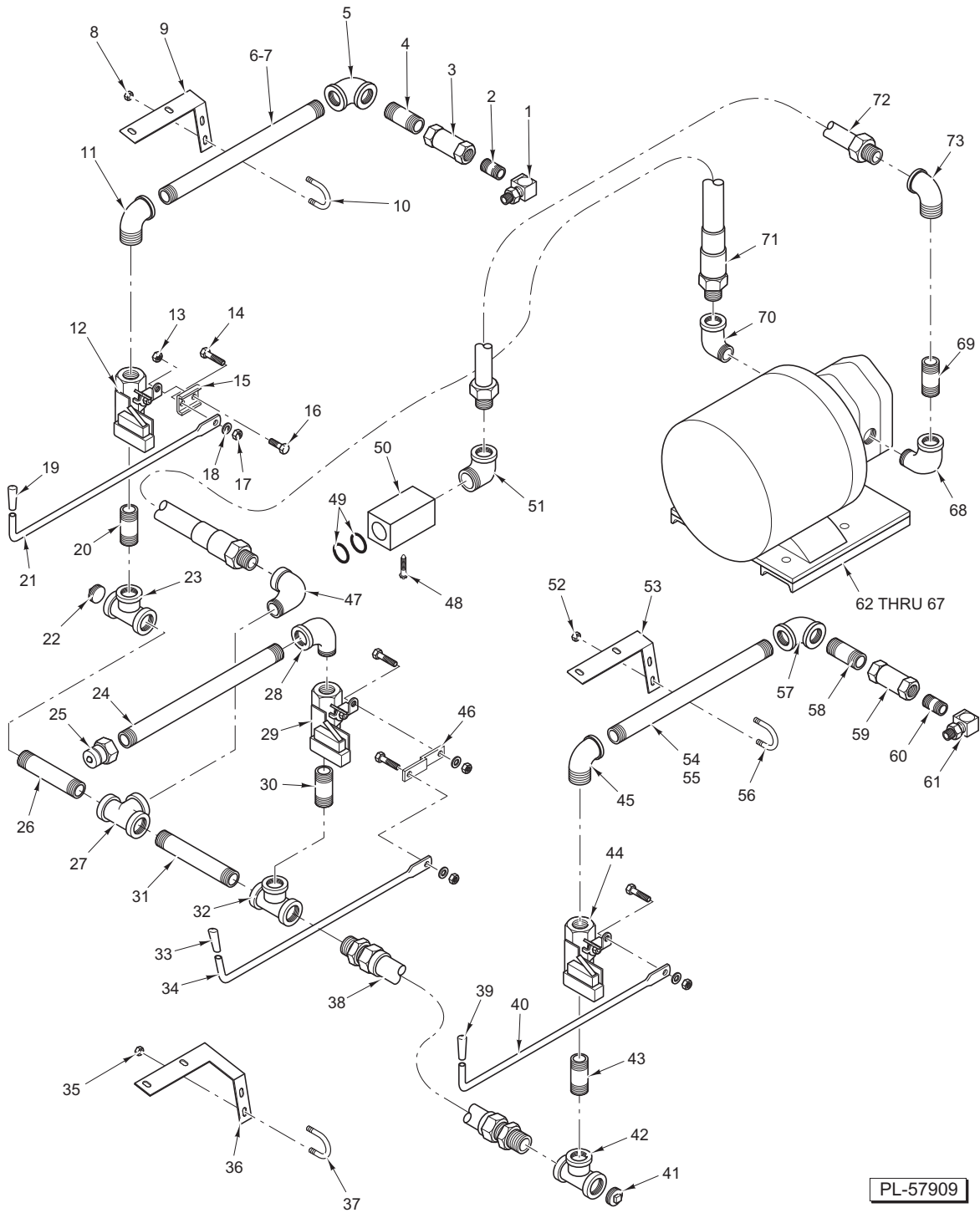

OIL RETURN (GR65MF AND GR85MF)

ILLUS.	PART NO.	NAME OF PART	AMT.
1	00-419251-00001	Fitting – 90 Deg. Swivel.....	1
2	FP-086-28	Pipe 1/2 x 7/8 TBE.....	1
3	00-418786-00001	Valve – Check.....	1
4	FP-086-29	Pipe 1/2 x 4 1/2 TBE.....	1
5	FP-077-68	Elbow 1/2 x 90 Deg.....	1
6	FP-059-86	Pipe 1/2 x 7 5/8 TBE (GR65MF).....	1
7	FP-058-49	Pipe 1/2 x 3 1/2 TBE (GR85MF).....	1
8	NS-046-52	Nut Assy. 1/4-20 Hex.....	2

OIL RETURN (GR65MF AND GR85MF) (CONT.)

ILLUS. PL-57909	PART NO.	NAME OF PART	AMT.
9	00-428955-00001	Bracket – Oil Return (Previous Construction)	1
10	00-521820	U-Bolt	1
11	FP-013-17	Elbow – Street 1/2 x 90 Deg	1
12	00-419291-000G1	Valve Assy.	1
13	NS-044-14	Nut Assy. 1/4-20 Hex KEPS	1
14	SC-113-34	Shoulder Screw 1/4-20 x 1/2 Hex Socket Hd.	4
15	00-428956-00001	Extension – Pull Rod (Previous Construction)	1
16	SC-110-12	Cap Screw 1/4-20 x 5/8 Hex Hd.	1
17	NS-044-14	Nut Assy. 1/4-20 Hex KEPS	4
18	WS-005-06	Washer	12
19	00-416435-00001	Grip (Red)	1
20	FP-035-94	Pipe 1/2 x 1 1/2 TBE	1
21	00-428693-00004	Rod – Pull Kleenscreen	1
22	FP-028-14	Pipe – Plug 1/2 Sq. Hd.	1
23	FP-019-25	Tee 1/2 x 1/2 x 1/2	1
24	FP-080-92	Pipe 1/2 x 16	1
25	00-418781-00001	Quick Disconnect	1
26	FP-086-29	Pipe 1/2 x 4 1/2 TBE	1
27	FP-019-25	Tee 1/2 x 1/2 x 1/2	1
28	FP-013-17	Elbow 1/2 x 90 Deg	1
29	00-419291-000G1	Valve Assy.	1
30	FP-035-94	Pipe 1/2 x 1 1/2 TBE	1
31	FP-058-51	Pipe 1/2 x 5 TBE	1
32	FP-019-25	Tee 1/2 x 1/2 x 1/2	1
33	00-416435-00002	Grip (White)	1
34	00-428693-00004	Rod – Pull Kleenscreen	1
35	NS-046-52	Nut Assy. 1/4-20 Hex	2
36	00-497087-00001	Bracket – Quick Disconnect	1
37	00-521820	U-Bolt	1
38	00-426602-00001	Tube – Flex (12 In.)	1
39	00-416435-00001	Grip (Red)	1
40	00-428693-00004	Rod – Pull Kleenscreen	1
41	FP-028-14	Pipe – Plug 1/2 Sq. Hd.	1
42	FP-019-25	Tee 1/2 x 1/2 x 1/2	1
43	FP-035-94	Pipe 1/2 x 1 1/2 TBE	1
44	00-419291-000G1	Valve Assy.	1
45	FP-013-17	Elbow – Street 1/2 x 90 Deg	1
46	00-426682-00001	Extension – Pull Rod (Previous Construction)	1
47	FP-013-17	Elbow – Street 1/2 x 90 Deg	1
48	SC-114-01	Mach. Screw 10-32 x 3/8 Hex Washer Hd.	1
49	00-426567-00002	O-Ring (Viton)	2
50	00-426567-00003	Receptacle – Oil Suction	1
51	FP-013-17	Elbow – Street 1/2 x 90 Deg	1
52	NS-046-52	Nut Assy. 1/4-20 Hex	2
53	00-428955-00001	Bracket – Oil Return (Previous Construction)	1
54	FP-059-86	Pipe 1/2 x 7 5/8 TBE (GR65MF)	1
55	FP-058-49	Pipe 1/2 x 3 1/2 TBE (GR85MF)	1
56	00-521820	U-Bolt	1
57	FP-077-68	Elbow 1/2 x 90 Deg	1
58	FP-086-29	Pipe 1/2 x 4 1/2 TBE	1
59	00-418786-00001	Valve – Check	1
60	FP-035-91	Pipe 1/2 x 1 1/8 TBE	1
61	00-419251-00001	Fitting – 90 Deg. Swivel	1
62	00-417792-00001	Pump Motor Assy. (120 V., 60 Hz.) (5.6 G.P.M.) (Previous Construction)	1
63	00-417792-00003	Pump Motor Assy. (208 V., 50/60 Hz.) (5.6 G.P.M.) (Previous Construction)	1
64	00-417792-00004	Pump Motor Assy. (230 V., 50/60 Hz.) (5.6 G.P.M.) (Previous Construction)	1
65	00-417792-00005	Pump Motor Assy. (115 V., 60 Hz.) (8 G.P.M.) (Current Construction)	1
66	00-417792-00006	Pump Motor Assy. (208 V., 50/60 Hz.) (8 G.P.M.) (Current Construction)	1
67	00-417792-00007	Pump Motor Assy. (230 V., 50/60 Hz.) (8 G.P.M.) (Current Construction)	1
68	FP-077-68	Elbow 1/2 x 90 Deg	1
69	FP-035-94	Pipe 1/2 x 1 1/2 TBE	1
70	FP-083-73	Elbow – Street 1/2 x 90 Deg. (Brass)	1
71	00-426602-00001	Tube – Flex (12 In.)	1
72	00-426602-00002	Tube – Flex (29 In.)	1
73	FP-077-68	Elbow 1/2 x 90 Deg	1
	00-411496-000F7	Micro Switch (Included With Items 12, 29, & 44)	1

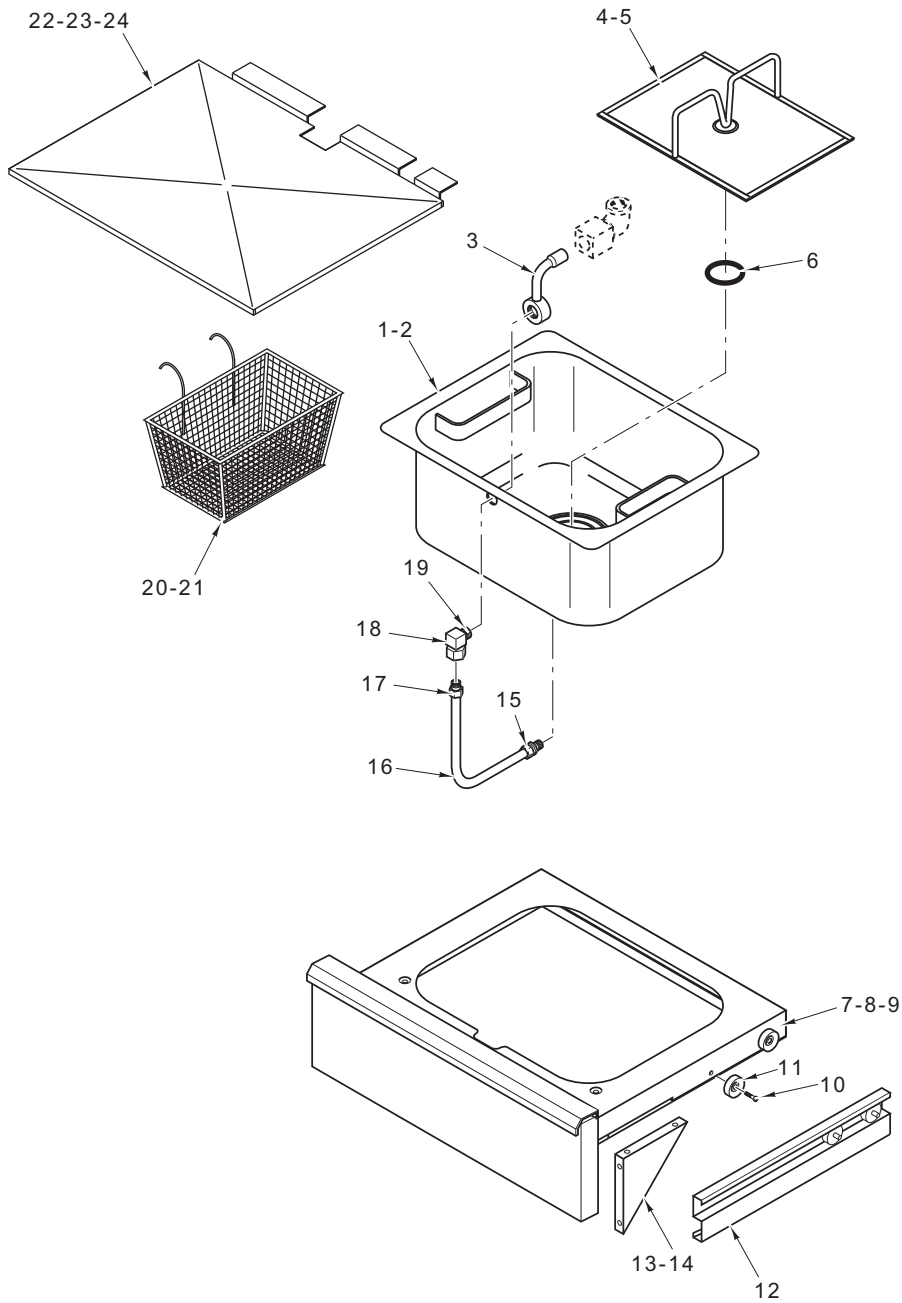

PL-57840

FILTER ASSEMBLY (PREVIOUS CONSTRUCTION)

FILTER ASSEMBLY (PREVIOUS CONSTRUCTION)

ILLUS. PL-57840	PART NO.	NAME OF PART	AMT.
*1	-	Vessel Assy. (GR45/65 Series).....	1
*2	-	Vessel Assy. (GR85 Series).....	1
3	00-427672-000G1	Pipe – Oil Return Assy.	1
4	00-426711-000G1	Element – Filter Assy. (GR45/65 Series)	1
5	00-426711-000G2	Element – Filter Assy. (GR85 Series and GR65 Series Built In 2006).....	1
6	00-426630-00002	Seal – O-Ring.....	1
7	00-428180-000G4	Drawer Assy. (GR45 Series) (Incls. Items 12 & 14).....	1
8	00-428180-000G2	Drawer Assy. (GR65 Series) (Incls. Items 10 thru 14).....	1
9	00-428580-000G1	Drawer Assy. (GR85 Series) (Incls. Items 10 thru 14).....	1
10	00-426600-00003	Screw 1/4-20	2
11	00-426600-00002	Bearing – Roller.....	2
12	00-426600-000G1	Roller Guide Assy.....	1
13	00-426595-00001	Gussett – Drawer Door.....	2
14	SD-032-07	Self-Tapping Screw 10-24 x 1/2 Hex Washer Hd., Type TT	AR
15	00-426601-00002	Fitting 3/8 Compression.....	1
16	00-497375-00001	Tube – Oil Return.....	1
17	00-426601-00001	Fitting 3/8 Compression.....	1
18	00-426568-00001	Elbow 3/8 NPT.....	1
19	FP-035-91	Pipe 1/2 x 1 1/8 TBE.....	1
20	00-426606-00001	Basket – Scrap (GR45/65 Series)	1
21	00-426606-00002	Basket – Scrap (GR85 Series)	1
22	00-428677-00001	Splash Guard (GR45 Series).....	1
23	00-428678-00001	Splash Guard (GR65 Series).....	1
24	00-428911-00001	Splash Guard (GR85 Series).....	1

* The Previous Construction Vessel Assembly is no longer available.

For GR45 Series Vessel Assembly, order the following:

00-499092-000G1	Tube – Suction.....	1
00-497374-000G1	Pan – Filter	1
00-426567-00003	Receptacle – Oil Suction	1
00-499487-000G3	Door Assy. (LH) (With Hinge).....	1
00-499487-000G4	Door Assy. (RH) (With Hinge)	1
00-426606-000G5	Basket – Scrap	1
00-499087-00001	Screen – Fine Mesh Filter.....	1
00-499085-00001	Insert – Filter Screen	1
00-426567-00002	O-Ring (Viton).....	2

For G65 Series Vessel Assembly, order the following:

00-428180-000G5	Drawer Assy.	1
00-497374-000G2	Pan – Filter	1
00-426567-00003	Receptacle – Oil Suction	1
00-499487-000G3	Door Assy. (LH) (With Hinge).....	1
00-499487-000G4	Door Assy. (RH) (With Hinge)	1
00-426606-000G6	Basket – Scrap	1
00-499092-000G1	Tube – Suction.....	1
00-499087-00001	Screen – Fine Mesh Filter.....	1
00-499085-00001	Insert – Filter Screen	1
00-426567-00002	O-Ring (Viton).....	2

For G85 Series Vessel Assembly, order the following:

00-499092-000G1	Tube – Suction.....	1
00-497374-000G2	Pan – Filter	1
00-426567-00003	Receptacle – Oil Suction	1
00-428180-000G5	Drawer Assy.	1
00-499487-000G7	Door Assy. (LH) (With Hinge).....	1
00-499487-000G8	Door Assy. (RH) (With Hinge)	1
00-426606-000G6	Basket – Scrap	1
00-499087-00001	Screen – Fine Mesh Filter.....	1
00-499085-00001	Insert – Filter Screen	1
00-426567-00002	O-Ring (Viton).....	2

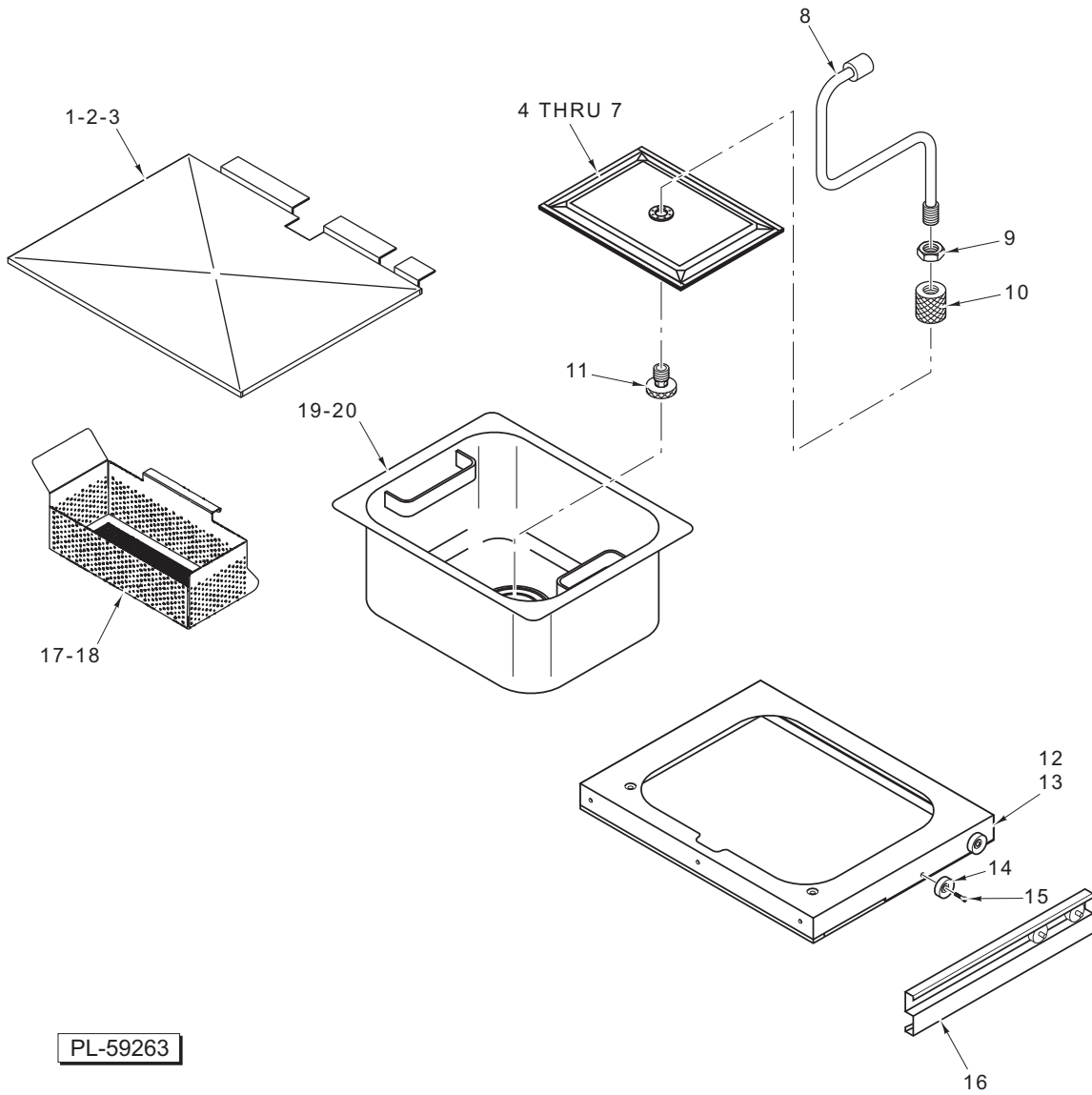

FILTER ASSEMBLY (CURRENT CONSTRUCTION)

FILTER ASSEMBLY (CURRENT CONSTRUCTION)

ILLUS. PL-59263	PART NO.	NAME OF PART	AMT.
1	00-428677-00001	Splash Guard (GR45 Series).....	1
2	00-428678-00001	Splash Guard (GR65 Series).....	1
3	00-428911-00001	Splash Guard (GR85 Series).....	1
4	00-499087-00001	Screen – Fine Mesh Filter.....	1
5	00-499085-00001	Insert – Filter Screen	1
6	00-499086-000G1	Filter – Kleenscreen Plus (3 Pack)	1
7	00-499089-00001	Clip – Filter.....	1
8	00-499081-000G3	Tube – Suction.....	1
9	NS-017-49	Jam Nut ³ / ₄ -16 Hex.....	1
10	00-499083-00002	Coupling.....	1
11	00-499084-00002	Knob	1
12	00-428180-000G4	Drawer Assy. (GR45 Series) (Incls. Item 16)	1
13	00-428180-000G5	Drawer Assy. (GR65\85 Series) (Incls. Item 16)	1
14	00-426600-00002	Bearing – Roller.....	2
15	00-426600-00003	Screw ¹ / ₄ -20	2
16	00-426600-000G1	Roller Guide Assy.....	1
17	00-426606-000G4	Basket – Scrap (GR45 Series)	1
18	00-426606-000G6	Basket – Scrap (GR65/85 Series)	1
19	00-497374-000G1	Vessel Assy. (GR45 Series).....	1
20	00-497374-000G2	Vessel Assy. (GR65/85 Series).....	1

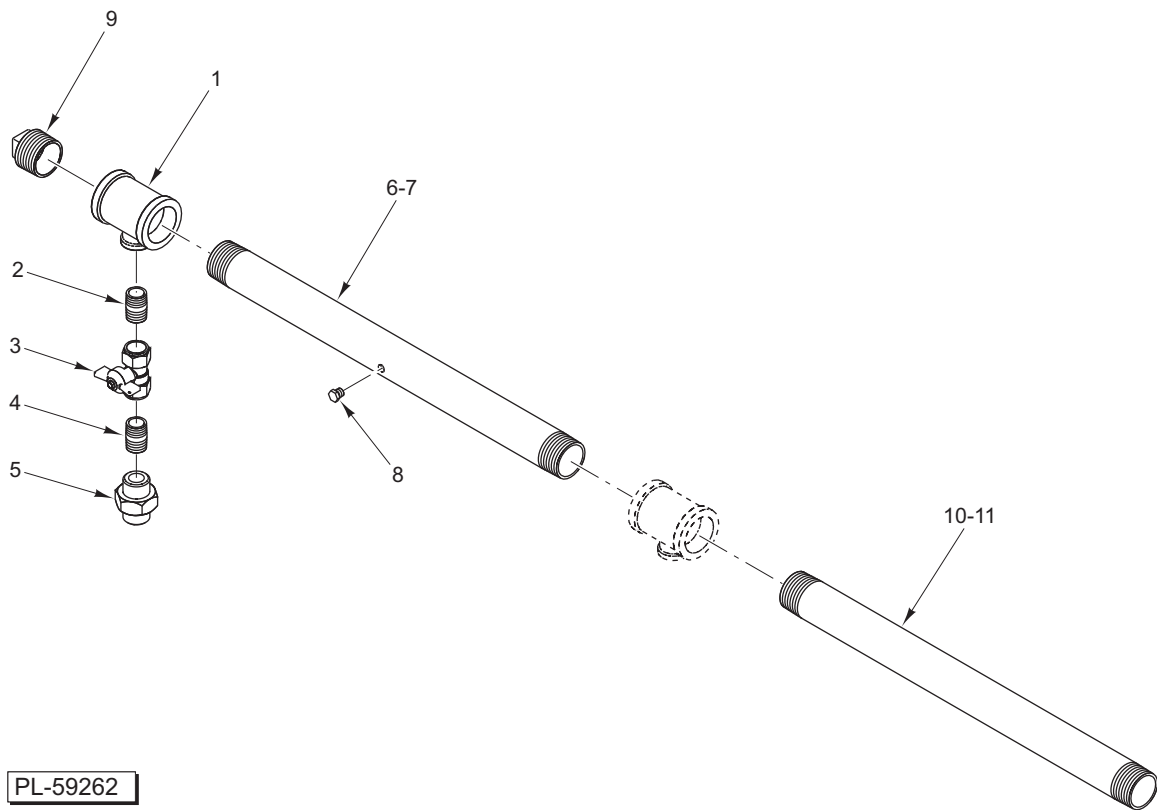

PL-59262

GAS INLET MANIFOLD

GAS INLET MANIFOLD

ILLUS.	PART NO.	NAME OF PART	AMT.
PL-59262			
1	FP-090-80	Tee 1 ¹ / ₄ x 1 ¹ / ₄ x 1 ¹ / ₂	AR
2	FP-035-91	Pipe 1 ¹ / ₂ x 1 ¹ / ₈ TBE.....	AR
3	00-428472-00001	Valve – Gas (1 ¹ / ₂ In.).....	AR
4	FP-035-91	Pipe 1 ¹ / ₂ x 1 ¹ / ₈ TBE.....	AR
5	FP-022-11	Union – Pipe	AR
6	00-957744-00001	Pipe – Rear Gas (With Tap) (2GR45, 3GR45, & 4GR45)	AR
7	00-957744-00002	Pipe – Rear Gas (With Tap) (2GR65, 2GR85, 3GR65, 3GR85, 4GR65, & 4GR85)	AR
8	FP-085-53	Plug – Pipe 1 ¹ / ₈ Hex Hd. (SST).....	AR
9	FP-028-26	Plug – Pipe 1 ¹ / ₄ Square Hd.	AR
10	00-957744-00004	Pipe – Rear Gas (Without Tap) (3GR45 & 4GR45)	AR
11	00-957744-00003	Pipe – Rear Gas (Without Tap) (3GR65, 3GR85, & 4RG85).....	AR
	00-419878-000G1	Manifold – Gas Inlet (2GR45) (Incls. Items 1 thru 6, 8, & 9).....	1
	00-419878-000G2	Manifold – Gas Inlet (3GR45) (Incls. Items 1 thru 6, 8, 9, & 10).....	1
	00-419878-000G7	Manifold – Gas Inlet (4GR45) (Incls. Items 1 thru 6, 8, 9, & 10).....	1
	00-419876-000G1	Manifold – Gas Inlet (2GR65, 2GR85, 4GR65, & 4GR85) (Incls. Items 1 thru 5, 7, 8, & 9)	1
	00-419876-000G2	Manifold – Gas Inlet (3GR65 & 3GR85) (Incls. Items 1 thru 5, 7, 8, 9, & 11)	1

